

OPERATING AND SERVICE MANUAL



MODEL 683C
SWEEP OSCILLATOR
SERIALS PREFIXED: 110 -



Copyright HEWLETT-PACKARD COMPANY 1961
1501 PAGE MILL ROAD, PALO ALTO, CALIFORNIA, U.S.A.

SPECIFICATIONS

FREQUENCY RANGE:	2 to 4 kmc (gc)
SWEEP RANGE:	2.1 mc to 2.1 kmc (gc) in 7 steps. Continuous control between steps.
RF SWEEP RATE OF CHANGE:	16 mc/sec to 160 kmc (gc)/sec in 9 steps
SWEEP TIME:	0.0135 sec to 135 sec for full band sweep; determined by sweep range and rate.
POWER OUTPUT:	Adjustable; 0 to at least 30 mw into 50-ohm load
POWER VARIATION:	With leveler operating: less than ± 1.5 db over entire frequency range. With leveler off: less than ± 3 db over entire frequency range.
RESIDUAL FM:	Less than 100 kc peak
SPURIOUS SIGNAL:	At least 20 db below cw output
MAXIMUM SWR:	2.5 or less
OUTPUT CONNECTOR:	Type N female
SWEEP MODE:	Recurrent; externally triggered (20 volts positive with better than 3 volts/ μ sec rate of rise); manually triggered. RF Frequency sweep is linear with respect to time and is downward from frequency dial setting.
SWEEP OUTPUT:	+25 volt (approximately) peak sawtooth provided concurrently with swept rf output for recorder and oscilloscope sweep. Source impedance 10,000 ohms and 20 pf in parallel.
SWEEP WIDTH:	Accuracy: $\bullet 10\%$ for full band sweep. +25%, -15% or ± 3 mc, whichever is greater for other calibrated sweep widths. Linearity: The half-voltage point of the SWEEP OUTPUT occurs within 5% of mid-frequency.
FREQUENCY DIAL ACCURACY:	$\bullet 1\%$
RESIDUAL AM:	Greater than 40 db below carrier amplitude
MODULATION:	<u>Internal AM:</u> Square wave modulation continuously adjustable from 400 to 1200 cps. Peak rf output power is within 1 db of the cw level. <u>External AM:</u> Direct coupled dc to 300 kc/sec; -20 volts or more reduces rf output level from rated cw output to zero. Input impedance: 750K ohms and 25 pf (approximately) in parallel. <u>External FM:</u> Approximately 150 volts peak-to-peak required to modulate full frequency range, 10 cps to 60 cps. Frequency deviation and modulating voltage must be decreased with modulating frequencies higher than 60 cps. Input impedance; 43K ohms and 100 pf (approximately) in parallel; ac coupled. <u>External Pulse:</u> +10 volts or greater pulse required; 5 millisecond maximum pulse length. Peak rf pulse level within 1 db of cw level. Pulse rise and decay times less than 1 μ sec. Input impedance: 390K ohms and 25 pf (approximately) in parallel; ac coupled.
POWER:	115 or 230 volts $\pm 10\%$, 50 to 60 cps approximately 540 watts
DIMENSIONS:	Cabinet Mount: 20-9/16 inches wide, 12-3/4 inches high, 18 inches deep Rack Mount: 17-5/8 inches wide, 10-1/8 inches high, 16-5/8 inches deep
WEIGHT:	Cabinet Mount: Net 105 lbs, shipping 134 lbs Rack Mount: Net 105 lbs, shipping 134 lbs

TABLE OF CONTENTS

Section	Page	Section	Page
I GENERAL INFORMATION		IV MAINTENANCE	
1-1. Description	1-1	4-1. General	4-1
1-2. Instrument Cooling System	1-1	4-2. General Precautions	4-1
1-3. Three-Conductor Power Cable	1-1	4-3. Air Filter	4-2
1-4. 230-Volt Operation	1-2	4-4. Cabinet Removal	4-2
1-5. Rack Mounting Instructions	1-2	4-5. Quick-Check Procedure	4-2
1-6. BWO Tube Information	1-3	4-6. Maintenance Test Equipment Required	4-6
II OPERATING INSTRUCTIONS		4-7. Magnet Supply (Regulated)	4-6
2-1. Contents	2-1	4-8. -150 Volt Regulated Supply	4-7
2-2. Installation	2-1	4-10. Helix Supply	4-7
2-3. Turn-On Procedure	2-1	4-11. Filament Regulated	4-9
2-4. Using the Sweep Oscillator as a CW Signal Source	2-2	4-12. Measurement of Linear Sweep Times Replacement of BWO Tube, and Calibration Procedure	4-9
2-5. Sweep Operation of the Oscillator	2-2	4-13. RF Sweep Linearity	4-10
2-6. Amplitude Modulating the Oscillator	2-2	4-14. Square-Wave Generator	4-15
2-7. Frequency Modulating the Oscillator	2-2	4-15. RF Leveler and Reference Anode Voltage Adjustment	4-15
2-8. Application	2-8	4-16. Servicing the Sweep Circuits	4-17
III THEORY OF OPERATION		4-17. Replacing Neon DC Coupling Elements	4-19
3-1. Contents	3-1	4-18. Positioning Frequency Dial on Potentiometer Shaft	4-19
3-2. Backward-Wave Oscillator Tube	3-1	4-19. Tube Replacement	4-22
3-3. RF Leveler and Anode Reference Circuit	3-3	4-20. Troubleshooting Procedure	4-22
3-4. Amplitude Modulator	3-4		
3-5. Helix Modulator	3-5	V REPLACEABLE PARTS	
3-6. Linear Sweep Generator	3-5	5-1. Introduction	5-1
3-7. Helix Supply Reference Voltage and Exponential Voltage Generators	3-8	5-2. Ordering Information	5-1
3-8. Regulated Power Supplies	3-10		
3-9. Magnet Current Supply (Regulated)	3-11		

LIST OF TABLES

Number	Title	Page
1-1.	Electronic Sweep Oscillators	1-1
3-1.	Condition of Tubes During CW and RF Sweep	3-9
4-1.	Tube Replacement Chart	4-23
4-2.	Troubleshooting Procedure	4-24
5-1.	Replaceable Parts	5-1

LIST OF ILLUSTRATIONS

Number	Title	Page	Number	Title	Page
1-1.	Warranty Sheet	1-2	4-1.	Measuring RF Power Output	4-2
2-1.	Turn-On Procedure and CW Operation .	2-0	4-2.	Checking Frequency Calibration and General Performance	4-3
2-2.	Using the Sweep Oscillator as a CW Signal Source	2-2	4-3.	Setup for Measuring Residual AM . . .	4-5
2-3.	Internal Sweep Modulation	2-3	4-4.	Measuring Magnet Circuit Ripple . . .	4-7
2-4.	Internal Square-Wave Modulation . . .	2-4	4-5.	Model 683C Top View	4-8
2-5.	External Pulse Modulation	2-5	4-6.	Sweep Output Voltage	4-9
2-6.	External Amplitude Modulation	2-6	4-7.	Model 683C Bottom View	4-12
2-7.	External Frequency Modulation	2-7	4-8.	Model 683C Rear View	4-12
2-8.	Allowable External Frequency Modulation Voltage Amplitude vs Modulation Voltage Frequency	2-8	4-9.	Positioning the BWO Tube at the Front and Rear of Magnet	4-13
2-9.	Suitable Setup for Measuring Frequency Deviation Limits when using External FM	2-9	4-10.	Calibration Pips on CRO Sweep	4-14
2-10.	Input and Output Connector Characteristics	2-10	4-11.	Example of Calibration Pips on CRO Sweep	4-15
3-1.	Backward-Wave Oscillator Tube Construction	3-1	4-12.	Crystal Detector-Attenuator Response Curve	4-16
3-2.	Block Diagram Model 683C Sweep Oscillator.	3-2	4-13.	RF Leveler Circuit Board	4-18
3-3.	RF Leveler Detected Waveform (Leveled and Unleveled Positions) . .	3-3	4-14.	RF Leveler Calibration Setup	4-19
3-4.	Adjustable Segments of Compensated Helix Voltage	3-3	4-15.	Model 683C Right Side View	4-20
3-5.	RF Leveler Circuit	3-4	4-16.	Model 683C Left Side View	4-21
3-6.	Amplitude Modulation EXT. Position .	3-5	4-17.	Sweep Output Voltage Linearity	4-22
3-7.	Frequency Modulator Waveforms	3-6	4-18.	Troubleshooting Chart	4-28
3-8.	Simplified Schematic of Sweep Circuit .	3-7	4-19.	Magnet Power Supply (Current Regulated)	4-30
3-9.	Simplified Schematic of Exponential Sweep Circuit	3-8	4-20.	Regulated Primary Power and Magnet Current Supply	4-31
			4-21.	Regulated +300 and -150 Volt PS	4-32
			4-22.	Frequency Supply and Low Voltage PS .	4-33
			4-23.	RF Power Leveler and Amplitude Modulator	4-34
			4-24.	Amplitude Modulator and Anode Section	4-35
			4-25.	Exponential and Linear Sweep Gen. . .	4-36
			4-26.	Frequency (Helix) Modulator	4-37

MODEL 683C

ELECTRONIC SWEEP OSCILLATOR

This manual specifically describes Model 683C of the T110 series, and in general describes all 683C sweep oscillators. If, however, the serial number of your instrument is prefixed by T024 or T044, there are parts of the manual which do not apply to your instrument. If your instrument carries one of these serial numbers, information specific to your instrument is furnished with this manual. This supplementary material includes schematics, parts list, and replacement paragraphs and illustrations for those items in the manual that do not describe your instrument. The supplementary data is indexed; paragraph and figure numbers are the same as those used in the manual for the corresponding information.

If it is necessary to order replacement parts, consult the supplementary parts list first. If the component is not listed, use the part number given in section V of the manual; otherwise, always use the part number in your supplementary parts list.

SECTION I

GENERAL INFORMATION

1-1. DESCRIPTION.

The Φ Model 683C Sweep Oscillator is one of several Φ Electronic Sweep Oscillators which cover major microwave bands as shown in table 1-1.

Table 1-1. Electronic Sweep Oscillators

Φ Model	Frequency Range
682C	1.0 to 2.0 kmc (gc)
683C	2.0 to 4.0 kmc (gc)
684C	4.0 to 8.1 kmc (gc)
H01 686C	7.0 to 11.0 kmc (gc)
686C	8.2 to 12.4 kmc (gc)
687C	12.4 to 18.0 kmc (gc)

Sweep oscillators are used as signal sources for a wide variety of laboratory and production tests. They provide a high-level relatively constant-amplitude signal that can be rapidly changed in frequency. Thus they permit the characteristics of microwave systems or components to be quickly checked over an entire band of frequencies.

The Φ Model 683C Sweep Oscillator covers the complete S band from 2 to 4 kmc (gc) and uses a backward wave oscillator (bwo) tube to generate the rf signal.

The bwo tube has several advantages over previously used klystron type microwave oscillator tubes when used in sweep sources.

The bwo tube output frequency and power level are determined by the values of applied voltage only. There are no cavity or reflector voltages to adjust or track. There is no tendency to switch modes of oscillation. Since frequency and power-level adjustments are electronic, all mechanical problems associated with tunable-cavity klystron-type oscillators are eliminated. Control of frequency and power level are simple, positive, and straightforward. By use of an rf leveler circuit, which programs the rf power output from the bwo input, power variations of ± 1.5 db are realized. With the rf leveler inoperative, output power from the bwo is kept constant within 6 db, but full power from the bwo tube is obtained. The rf output power is adjustable from 0 to a maximum which is not less than 30 milliwatts.

The Model 683C Sweep Oscillator is versatile. The output can be either cw or amplitude modulated. An internal square-wave source provides square-wave modulation at any frequency between 400 and 1200 cps. The instrument can be externally pulse modulated or

amplitude modulated by sine or complex waveforms at any percentage from 0 to 100%. In addition the oscillator can be externally frequency modulated or swept in frequency over any portion or all of the 2- to 4-kmc (gc) range, or if desired the 683C can be simultaneously amplitude and frequency modulated.

When used for its primary purpose as a sweep oscillator, the internal circuitry provides an extremely wide choice of sweeping rates and bandwidth swept. The rate of change of frequency is linear with time and adjustable in calibrated steps from 16 mc/sec to 160 kmc(gc)/sec. The frequency range swept can be as small as 2.1 mc or as wide as 2.1 kmc (gc), as selected by the calibrated seven position Δ FREQUENCY switch. In addition, there is a VERNIER control associated with the Δ FREQUENCY switch which gives continuous adjustment between the fixed positions.

The minimum sweep time of the Model 683C is 13.2 milliseconds. The sweep time is determined by the combined settings of the RF SWEEP RATE and the Δ FREQUENCY switches. These switches are interlocked by a differential gear drive which automatically prevents any combination which would produce a sweep time less than 13.2 milliseconds.

The swept rf output frequency from the oscillator is linear with time and, by adjustment of the SWEEP SELECTOR switch, can be made recurrent or set for single sweeps. Single sweeps are started either by the front-panel pushbutton or by an external positive pulse (rise time greater than 3 volts per microsecond). In addition, a sawtooth voltage of approximately 25 volts is provided concurrent with each rf sweep to supply a linear time base for an oscilloscope or X-Y recorder.

1-2. INSTRUMENT COOLING SYSTEM.

The instrument is forced-air cooled by a high velocity fan system. The incoming air is filtered to remove excessive dust. This filter must be inspected frequently to insure that it is not clogged with dirt. A dirty filter may restrict air flow sufficiently to cause excessive heating of the instrument which can cause early component failure (see figure 4-3).

1-3. THREE-CONDUCTOR POWER CABLE.

To protect operating personnel, the National Electrical Manufacturers' Association (NEMA) recommends that the instrument panel and cabinet be grounded. All Hewlett-Packard instruments are equipped with a three-conductor power cable which, when plugged into an appropriate receptacle, grounds the instrument. The offset pin on the power cable three-prong connector is the ground pin.

To preserve the protection feature when operating the instrument from a two-contact outlet, use a three-prong to two-prong adapter and connect the green pigtail on the adapter to ground.

1-4. 230-VOLT OPERATION.

The Φ Model 683C is usually shipped wired for 115 vac operation, but is quickly and easily converted to operation from a nominal 230-volt 50/60 cps source. To convert, remove two jumpers between terminals A2 and A3. In addition, remove the jumper wire (connecting the two rear terminals of the MAGNET 3 AMP and H. V. 3 AMP. fuses) from the rear terminal of the H.V. fuse and reconnect to the side terminal of the H.V. fuse. This side terminal also has a pink lead attached to it. Do not change the size of either the MAGNET fuse or the H.V. fuse. When operating from a 230-volt source, T101, the magnet supply and the fan operate on 115 volts supplied by T1 primary windings which act as a 2:1 autotransformer. This additional load is added to the normal load carried by the H.V. fuse and approximately offsets the expected reduction in current due to 230-volt operation.

1-5. RACK MOUNTING INSTRUCTIONS.

When mounting a rack model instrument, leave at least three inches clearance behind the air intake to insure proper air circulation. In addition, be certain that the air intake is not near another piece of equipment which is discharging hot air in the vicinity of the Model 683C air intake.

The following instructions should be followed for easy installation of a rack model instrument (683CR) in an equipment rack.

- 1) Remove the four screws from the rear of the instrument cabinet and slide the instrument forward from the cabinet.
- 2) Mount the empty cabinet in the equipment rack with four oval head machine screws: two screws on each side of the cabinet in the mounting holes approximately 1-3/4 inches from the top and bottom edges of the mounting flanges.
- 3) Raise the instrument chassis and slide it gently into the cabinet. Be certain the power cable passes freely through the hole in the rear of the cabinet.

MICROWAVE TUBE WARRANTY CLAIM
INFORMATION FORM

WARRANTY CLAIM AND ADJUSTMENT PROCEDURE

for microwave tubes supplied by the
HEWLETT-PACKARD COMPANY
for use in Φ instruments

Microwave tubes supplied by the Hewlett-Packard Company, either as original or replacement, for use in Φ instruments are actually warranted by the tube manufacturer and not by Φ . However, Φ will process warranty claims for you, and will promptly pass on all allowances granted by the tube manufacturer.

In the event that your tube is found to be repairable, the tube manufacturer reserves the right to repair and return the tube in lieu of issuing pro-rata credit.

For your convenience, warranty claims for all microwave tubes supplied by the Hewlett-Packard Company may be made on this single form; merely fill out the information on the reverse side and return this form, along with the defective tube, to your Φ engineering representative, or to Φ . Please be sure each space on the form is filled in--lack of complete information may delay processing of your claim.

Each tube manufacturer has his own warranty policy. Copies of individual Conditions of Warranty are available from your Φ engineering representative or from the Hewlett-Packard Company.

SHIPPING INSTRUCTIONS

The following instructions are included to aid you in preventing damage in transit. Package your tube carefully -- no allowance can be made on broken tubes.

1. Carefully wrap tube in 1/4 inch thick "kimpack", cotton batting, or other soft padding material.
2. Wrap the above in heavy kraft paper.
3. Pack in a rigid container which is at least 4 inches larger than the tube in each dimension.
4. Surround the tube with at least 2 inches of shock absorbing material. Be certain that the packing is tight all around the tube.
5. Tubes returned from outside the continental United States should be packed in a wooden box.
6. Mark container FRAGILE and ship prepaid via Air Freight or Railway Express. Do not ship via Parcel Post or Air Parcel Post since experience has shown that fragile items are more apt to be damaged when shipped by these means.

Tubes returned to the Hewlett-Packard Company should be addressed to:

CUSTOMER SERVICE
Hewlett-Packard Company
395 Page Mill Road
Palo Alto, California, U.S.A.

OR (In Western Europe)
Hewlett-Packard S.A.
Rue du Vieux Billard No. 1
Geneve, Switzerland

IMPORTANT: Please answer all questions fully -- insufficient information may delay processing of your claim.

FROM: (Tube Owner)	Date _____
Company _____	FOR FURTHER INFORMATION CONTACT:
Address _____	Name _____
_____	Title _____
_____	Company _____
Tube type _____	Address _____
Tube serial No. _____	_____
Tube mfr. _____	Tube purchased from _____
Use in Φ Model _____	_____
Instrument serial no. _____	On P. O. number _____
Tube is Original () or Replacement ()	_____
Date tube received _____	Hours use per day (average) _____
Date first tested _____	Number of days in service _____
Date placed in service _____	Total hours filament operation _____
Date of failure _____	_____

SYMPTOMS: (Please describe conditions prior to and at time of failure, along with description of tube's defect, if known) _____

Were there other circuit component failures at time of failure? Which ones?

Signature _____

Title _____

9/12/61

Figure 1-1. Warranty Sheet

- 4) Fasten the instrument panel securely to the rack.
- 5) Replace the four screws at the rear of the cabinet (if desired).

Note

This instrument weighs over 100 pounds. If the rack installation is subject to vibration or rough handling, additional means of support should be provided at the rear of the instrument.

1-6. BWO TUBE INFORMATION.

The bwo tube used in this instrument is very expensive and has a shorter guaranteed life than that of conventional tubes. See the Tube Warranty sheet, figure 1-1, for details. A sheet for your use is included in the appendix of this manual. To increase the number of useful hours of service obtained from each tube, it is suggested that the instrument be turned off when not in use. When replacing the bwo tube, the Backward-Wave Oscillator Tube Claims and Adjustment Procedure sheet in this manual should be read and the instructions followed carefully.

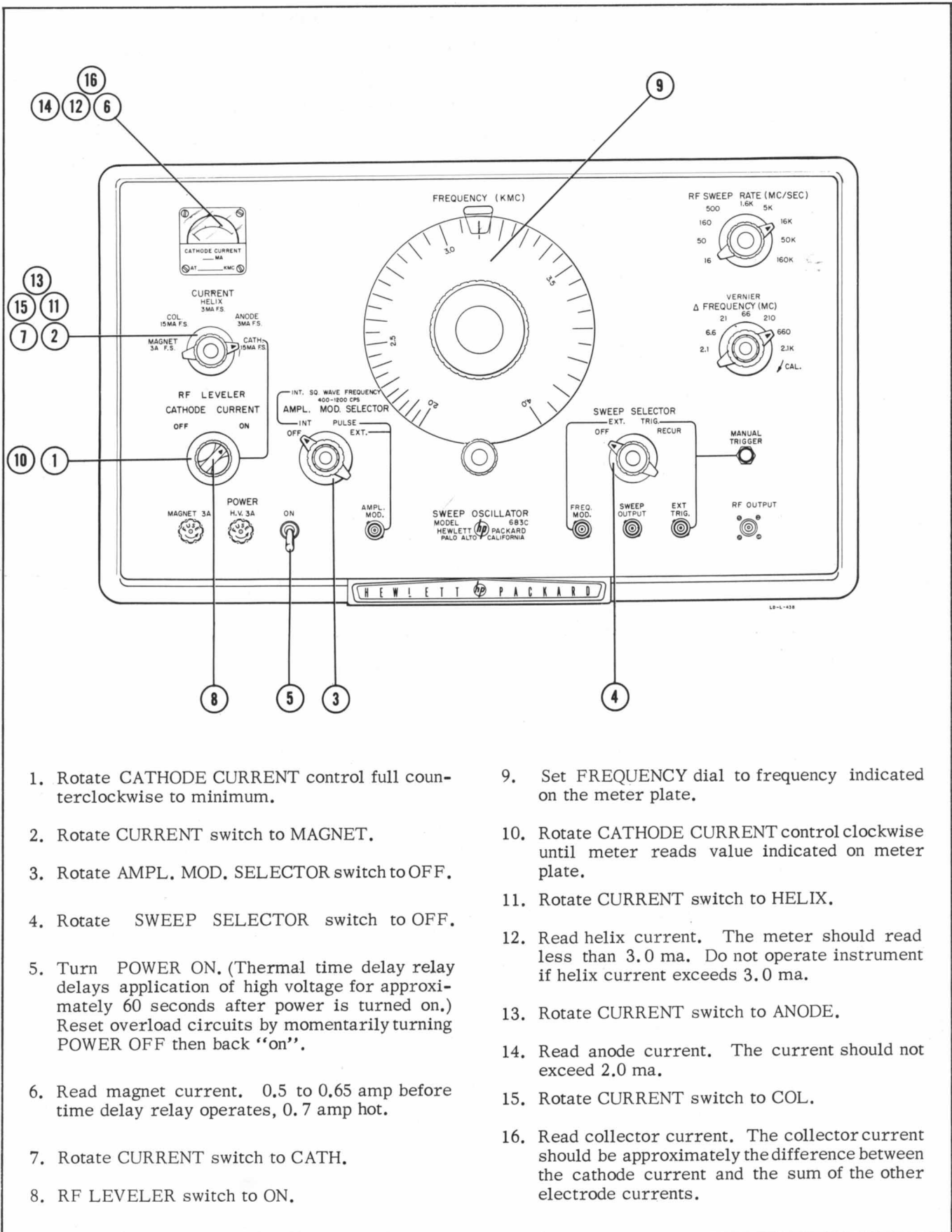

1. Rotate CATHODE CURRENT control full counterclockwise to minimum.
2. Rotate CURRENT switch to MAGNET.
3. Rotate AMPL. MOD. SELECTOR switch to OFF.
4. Rotate SWEEP SELECTOR switch to OFF.
5. Turn POWER ON. (Thermal time delay relay delays application of high voltage for approximately 60 seconds after power is turned on.) Reset overload circuits by momentarily turning POWER OFF then back "on".
6. Read magnet current. 0.5 to 0.65 amp before time delay relay operates, 0.7 amp hot.
7. Rotate CURRENT switch to CATH.
8. RF LEVELER switch to ON.
9. Set FREQUENCY dial to frequency indicated on the meter plate.
10. Rotate CATHODE CURRENT control clockwise until meter reads value indicated on meter plate.
11. Rotate CURRENT switch to HELIX.
12. Read helix current. The meter should read less than 3.0 ma. Do not operate instrument if helix current exceeds 3.0 ma.
13. Rotate CURRENT switch to ANODE.
14. Read anode current. The current should not exceed 2.0 ma.
15. Rotate CURRENT switch to COL.
16. Read collector current. The collector current should be approximately the difference between the cathode current and the sum of the other electrode currents.

Figure 2-1. Turn-On Procedure and CW Operation

SECTION II

OPERATING INSTRUCTIONS

2-1. CONTENTS.

Section II contains instructions for setting up and operating the sweep oscillator, instructions for modulating the rf output, and a discussion of some applications of the instrument.

2-2. INSTALLATION.

The Model 683C Sweep Oscillator should be placed on a work bench or table with at least 3 inches of clearance at the rear to insure adequate air flow through the filter. To avoid seriously restricted air flow, be careful not to let loose pieces of paper, etc. remain in the rear area since they can be pulled against the air filter.

The power cable should be used in a NEMA approved standard three-prong grounding receptacle (paragraph 1-3).

Complete installation instruction for rack model instruments are given in paragraph 1-5.

2-3. TURN-ON PROCEDURE.

Good operating practice dictates that you follow a given step-by-step procedure when turning on the Model 683C, to protect the two tube. This routine will systematically check out proper operation of all critical circuits to insure normal operation.

Under normal operation no damage can be done by improper setting of front panel controls since built-in overload protection cuts off primary power to the high-voltage transformer if excessive current flows in the helix circuit. The overload circuits are reset by momentarily turning off power to the instrument.

In addition to the overload protection, internal screwdriver-adjust controls preset limits on front panel controls to safe values. BWO tube currents are monitored with built-in metering circuits, which provide a positive check that the two tube is being operated in a safe manner.

To place the instrument in operation, the steps outlined in figure 2-1 should be followed in the order given. Additional data on some of the steps are given below under STEPS; before performing the turn-on procedure for the first time, read this supplemental information.

Figure 2-1 shows the front panel controls as well as briefly describing the steps of the turn-on procedure. The unnumbered controls and terminals can be operated in any order desired, depending on the type of operation selected. Characteristics of the input and output connectors are given in figure 2-10.

With the completion of the turn-on procedure the instrument is set up for cw operation at the frequency set on the FREQUENCY dial. Once cw operation has

been established, the oscillator may be adjusted for frequency and for amplitude modulation (paragraphs 2-4 through 2-7).

Until thoroughly familiar with instrument operation, it is recommended that you refer to the supplemental information which follows.

STEPS:

The number associated with each paragraph refers to the turn-on procedure step under discussion. See figure 2-1 for the steps not discussed below.

5. Set POWER to ON. The plastic graticule at the top of the FREQUENCY dial will glow. The cooling fan will operate. A thermal time-delay switch delays application of high voltage to the main circuits approximately 60 seconds after the instrument is energized. The magnet supply circuits are partly energized when the POWER switch is turned on, but do not regulate until the time-delay switch has operated and the filaments in the regulator circuits are energized.
6. Read magnet current on the monitor meter. The current should be 0.5 to 0.65 ampere when first turned on and will gradually settle to 0.70 ampere after a few minutes operation. **DO NOT OPERATE INSTRUMENT IF AFTER WARMUP THE MAGNET CURRENT IS NOT BETWEEN 0.675 AND 0.725 AMPERE.**
8. With RF LEVELER switch to ON the 683C will have a power output variation across the band of ± 1.5 db or less. In the RF LEVELER OFF position the power variation across the band will not exceed ± 3 db.
9. It is important that the meter reads the exact cathode current at the frequency indicated on the meter plate. The reasons are: a) Only with the rated cathode current at the frequency specified will adequate power be produced. b) If the latter conditions are not met, the RF LEVELER will not give the desired leveling action (± 1.5 db).
10. Rotate CATHODE CURRENT control in a clockwise direction and observe the current reading. Normal (at least 30 milliwatts) output will be obtained with the value of cathode current stamped on the panel meter. (The maximum current is limited by internal adjustments.)
12. Read helix current. The current should be less than 3 ma. **DO NOT OPERATE THE INSTRUMENT IF THE HELIX CURRENT EXCEEDS 3 MA.** An overload relay prevents excessive helix current. To reset the relay, momentarily turn POWER off, then back to ON. Excessive helix current may indicate misalignment of the two tube in the magnetic field (see section IV, Maintenance).

Verify proper operation of the helix power supply by rotating the FREQUENCY dial from 2 to 4 kmc (gc) and noting that there is a variation in helix current. (BWO helix current varies with a change in helix voltage. Thus a variation in helix current as the FREQUENCY dial is turned through its range is a check that helix voltage is changing.)

16. The collector current reading should be the difference between cathode current and the sum of the helix and anode current readings. If there is a large difference between this value of collector current and that shown by the meter, the instrument is not functioning properly (see section IV).

The instrument is now operating normally and generating a 30 milliwatt or more cw signal at the frequency indicated by the FREQUENCY dial.

2-4. USING THE SWEEP OSCILLATOR AS A CW SIGNAL SOURCE.

Upon completion of the turn-on procedure, the instrument is set up for cw operation. However, check that the AMPL. MOD. SELECTOR switch is OFF; RF LEVELER to ON. In cw operation, output frequency is indicated by the FREQUENCY dial to an accuracy of better than $\pm 1\%$.

The output power level is adjustable from at least 30 milliwatts down to zero by the CATHODE CURRENT control. Monitor the cathode current when adjusting the power level near rated value to insure that tube ratings are not being exceeded. If cathode current higher than 7 ma is required to get rated power, and helix current is higher than 3 ma, set cathode current to 7 ma and check that helix current is less than 3 ma. This is a check that tube focus is correct. (Focusing the bwo is discussed in paragraph 4-13B.)

By the addition of a precision attenuator, the 683C can be used as a signal generator. Figure 2-2 indicates connection of equipment for such a setup. A 20-db fraction of the power in the line is coupled to the

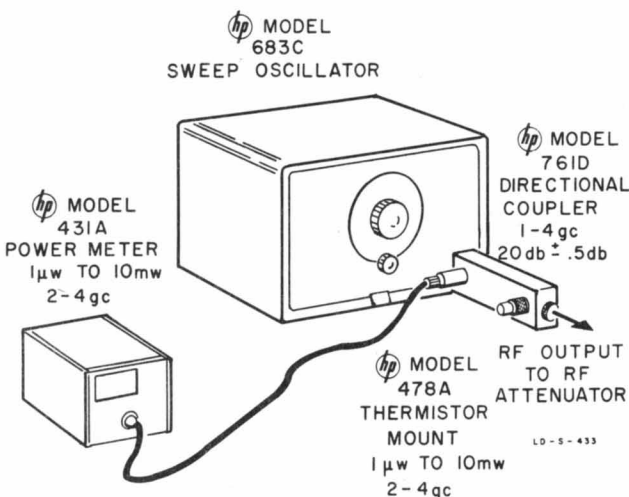

Figure 2-2. Using the Sweep Oscillator as a CW Signal Source

auxiliary arm of the 761D Dual Directional Coupler. The power-monitoring branch is taken from this auxiliary arm. Thus the rf power in the line is the reading on the 431A Power Meter plus 20 db, and the rf power at the load is the monitored rf power minus the setting of the attenuator. The accuracy with which the power reaching the load can be monitored in this way is limited by the accuracy of the attenuator. Rated accuracies of the other components are shown in figure 2-2.

2-5. SWEEP OPERATION OF THE OSCILLATOR.

After the oscillator has been set up for cw operation the rf output should be set to the desired power level and the FREQUENCY dial set to the proper setting. Refer to figure 2-3, for instructions on how to obtain sweep operation.

2-6. AMPLITUDE MODULATING THE OSCILLATOR.

The 683C provides facilities for modulation with internally-generated square waves, externally-supplied pulses (683C input, ac coupled), or externally supplied voltages (683C input, dc coupled). Operation at various positions of the switch are described in figures 2-5, 2-6, and 2-7.

2-7. FREQUENCY MODULATING THE OSCILLATOR.

The oscillator can be frequency-modulated from an external source by placing the SWEEP SELECTOR switch in the EXT. position and applying a modulating voltage to the FREQ. MOD. jack (figure 2-7). The jack is ac coupled to an impedance of 43K shunted by approximately 100 pf.

The bwo rf output frequency varies with respect to the voltage at the input to the FREQ. MOD. jack from approximately 8.2 mc/volt at 4 kmc (gc) to 23.8 mc/volt at 2 kmc (gc). The full frequency band (2.1 kmc [gc]) may be swept (at a rate of between 10 to 60 cps) by applying a voltage of 150 volts peak-to-peak to the FREQ. MOD. jack. When sweeping full band, the FREQUENCY dial should be set at approximately 3.2 kmc (gc). Frequency modulation is up and down from the frequency indicated on the FREQUENCY dial. Positive-going voltage applied to the FREQ. MOD. jack increases the frequency.

When the full band is swept, the frequency of the modulation voltage should be within 10 and 60 cps. When the frequency of the modulation voltage is higher than 60 cps, the band swept must be reduced to avoid overload of the helix power supply. The chart shown as figure 2-8 shows the maximum voltages which should be applied to the FREQ. MOD. jack when modulating frequencies above 60 cps are used.

For external frequency modulation of the 683C, consideration must be given to the modulation characteristics of the bwo. A linear change in modulation voltage produces an exponential change in the frequency of the rf output. If small modulation voltages are used,

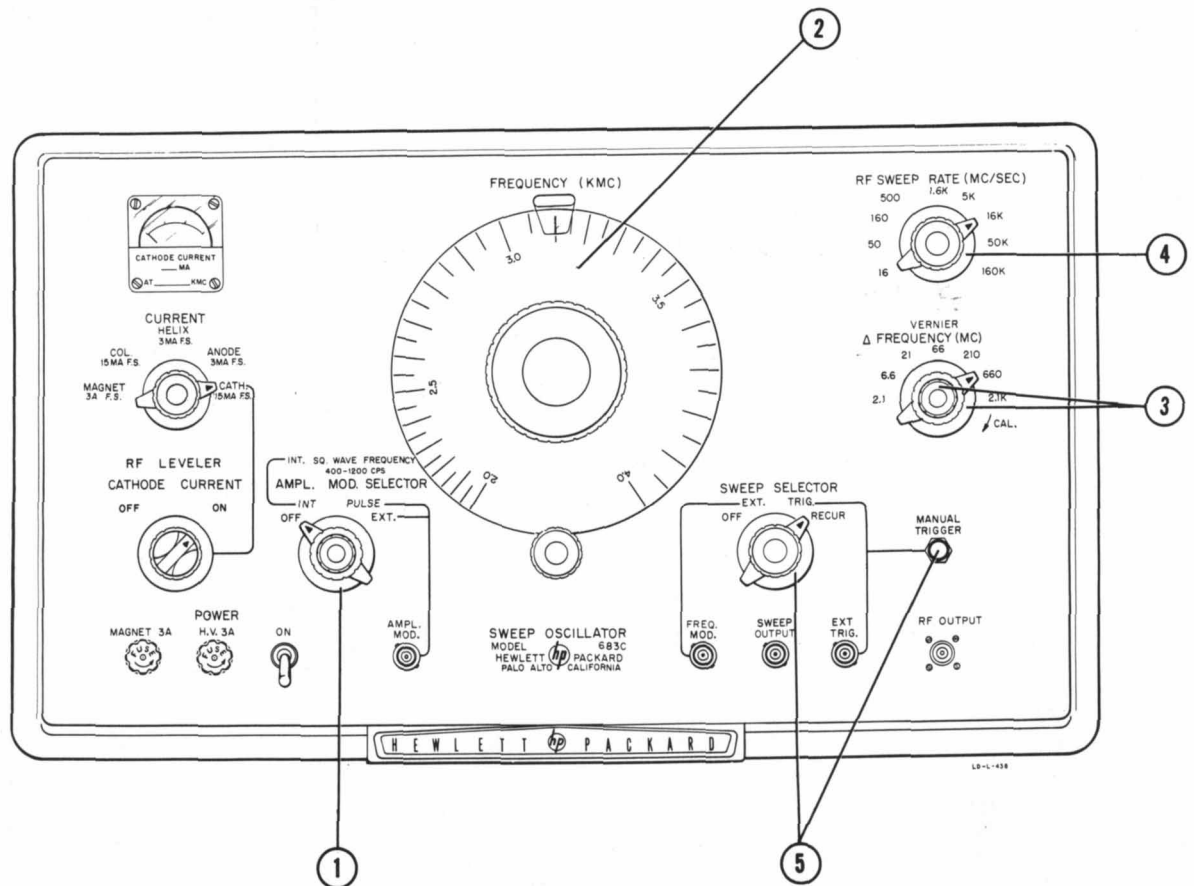

First turn on instrument and adjust for normal output under cw operation as shown in the turn-on procedure (figure 2-1).

1. Rotate the AMPL. MOD. SELECTOR switch to OFF, or other desired mode.
2. Set FREQUENCY (KMC) dial to 4 kmc (gc) (sweep is downward from FREQUENCY dial setting).
3. Rotate Δ FREQUENCY switch to position corresponding to number of megacycles to be swept. Set VERNIER to CAL. For variable length segments of Δ FREQUENCY, rotate out of CAL.
4. Rotate the RF SWEEP RATE switch to the position corresponding to the rate of sweep desired in mc/sec.

The Δ FREQUENCY switch and the RF SWEEP RATE switch are mechanically interlocked to prevent a combination of settings that would result in a sweep time of less than 0,0137 second.

5. Rotate SWEEP SELECTOR switch to RECUR if automatically recurring sweeps are desired.
6. Rotate SWEEP SELECTOR switch to TRIG, if single sweeps are desired. Sweeps may be started by momentarily pressing MANUAL TRIGGER button, or by supplying a positive 20-volt pulse to EXT. TRIG. jack.

CHARACTERISTICS -

Direction:

RF sweeps are downward, starting at the frequency indicated on the FREQUENCY (KMC) dial.

SWEEP OUTPUT voltage is a positive going 20-25 volt sawtooth voltage.

Accuracy:

Frequency band swept is within $\pm 10\%$ for full sweep. +25%, -15% or ± 3 mc, whichever is greater, for sweep widths less than full band.

Figure 2-3. Internal Sweep Operation

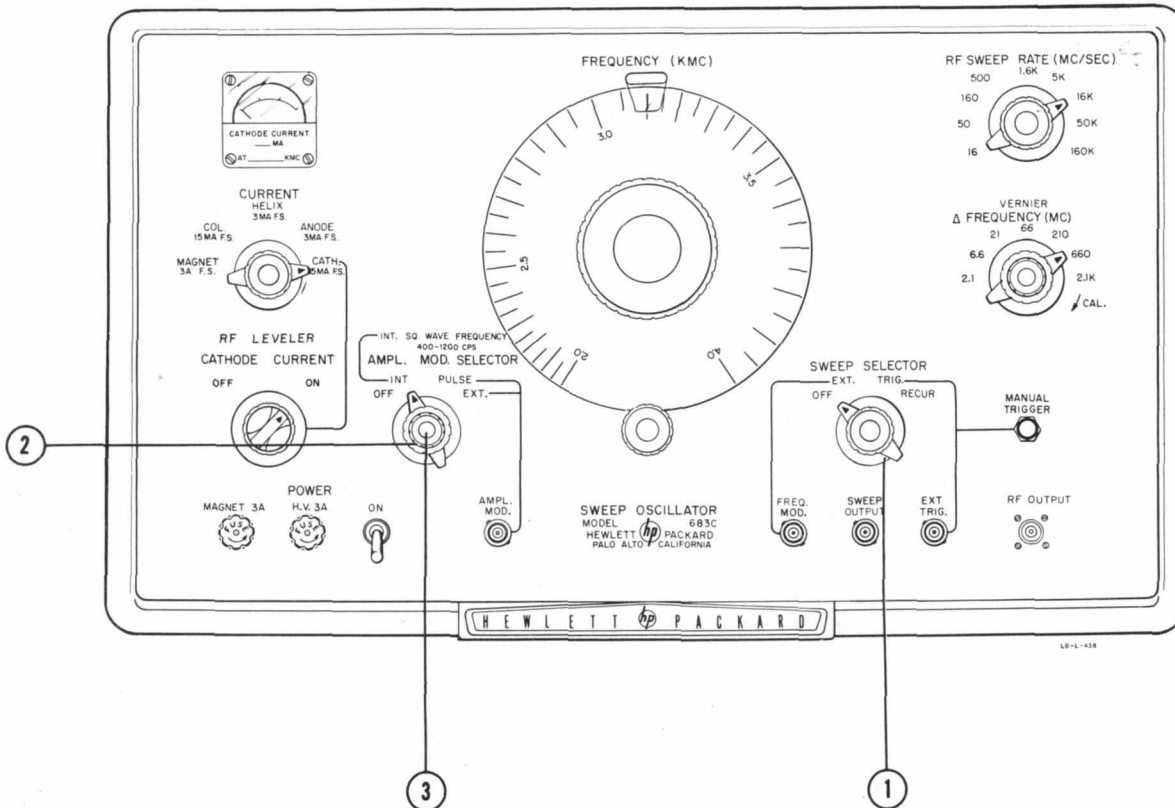

First turn on instrument and adjust for normal output under cw operation as shown in the turn-on procedure (figure 2-1).

1. Rotate SWEEP SELECTOR switch to OFF.
2. Rotate AMPL. MOD. SELECTOR switch to INT.
3. Adjust INT. SQ. WAVE FREQUENCY with red concentric knob.

CHARACTERISTICS -

Range:
400 to 1200 cps

Symmetry:

Better than 40% to 60%

Rise and Decay Time:

Less than 2 microseconds

RF Output:

During "on" time, rf output is within 1 db of established cw level. During "off" time, rf output is zero. RF output frequency is within 4 mc of the cw frequency.

Note: The AMPL. MOD. SELECTOR and SWEEP SELECTOR switches operate independently. Both may be set in any position at any time. Thus two types of modulation may be obtained simultaneously.

Figure 2-4. Internal Square-Wave Modulation

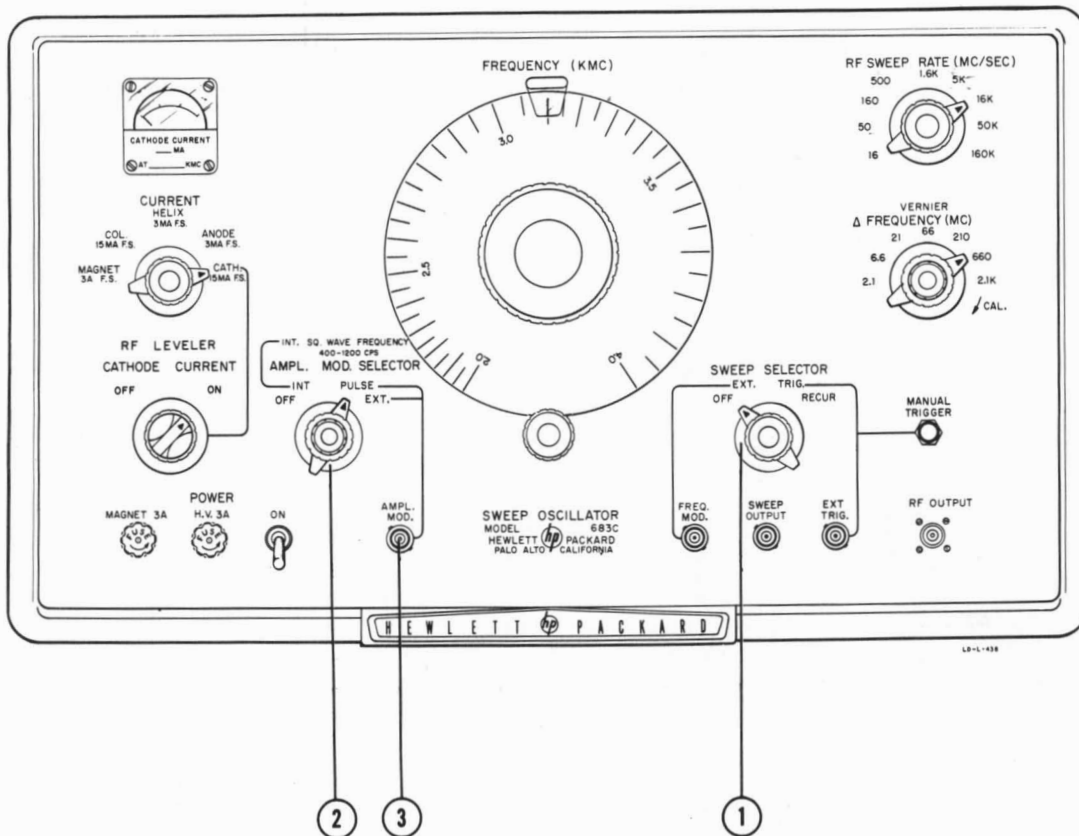

First turn on instrument and adjust for normal output under cw operation as shown in the turn-on procedure (figure 2-1).

1. Rotate SWEEP SELECTOR switch to OFF.
2. Rotate AMPL. MOD. SELECTOR switch to PULSE.
3. a) Feed a +10 to +30 volt signal, 5 milliseconds or less in width, at frequencies from 100 cps to 300 kc into the AMPL. MOD. jack.
b) A square wave -10 volts or more can also be applied to the AMPL. MOD. jack.

CHARACTERISTICS -

RF Output:

During "on" time, rf output is within 1 db of established cw level. During "off" time, rf output is zero. RF output frequency is within 4 mc of the cw frequency.

Note: The AMPL. MOD. SELECTOR and SWEEP SELECTOR switches operate independently. Both may be set in any position at any time. Thus two types of modulation may be obtained simultaneously.

Figure 2-5. External Pulse Modulation

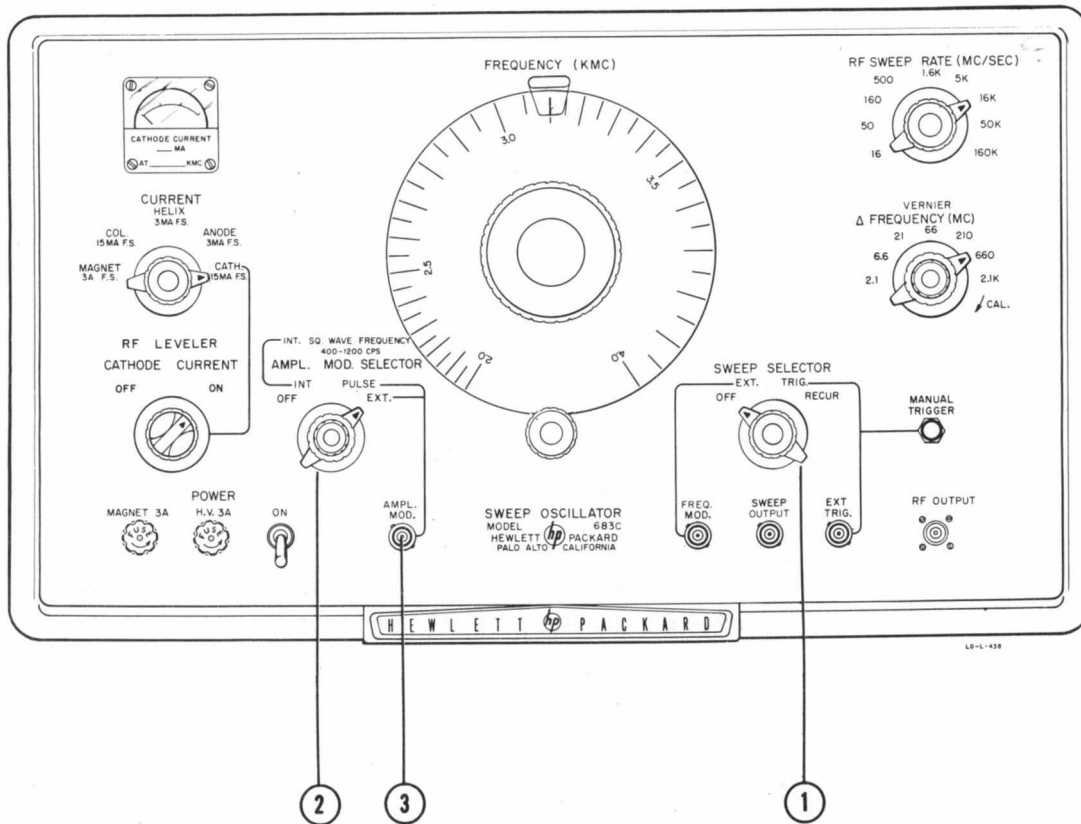

First turn on instrument and adjust for normal output under cw operation as shown in the turn-on procedure (figure 2-1).

1. Rotate SWEEP SELECTOR switch to OFF.
2. Rotate AMPL. MOD. SELECTOR switch to EXT.
3. Feed modulation voltage of 20 volts or more from an external source into AMPL. MOD. jack.

Note: Positive input pulse can be applied providing it is either capacitively coupled or superimposed on a -20 volt bias. If capacitively coupled the capacitor must be sufficiently large and the duty cycle such, as to maintain a charge (grid bias) between modu-

lation pulses. However, if the signal source has a large internal capacitor in series with the output, (example Model 212A) no external capacitor is needed.

CHARACTERISTICS -

- Modulation: Direct coupled, dc to 300 kc
- a) A modulation voltage of -20 volts applied to the AMPL. MOD. jack.
 - b) A +20 volt signal is applied to the AMPL. MOD. jack, providing a -20 volt bias is applied externally.

Automatic Gain Control:
Since the EXT. position is dc coupled, it applies itself very well to external automatic gain control.

Figure 2-6. External Amplitude Modulation

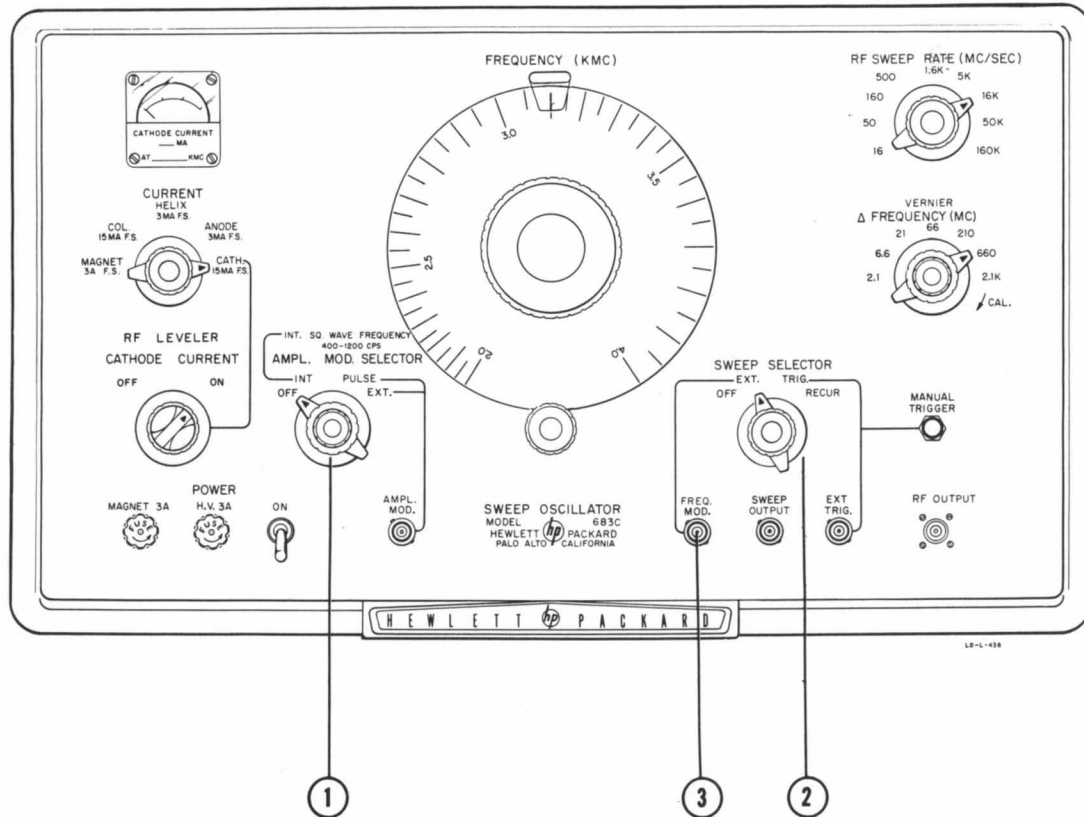

First turn on instrument and adjust for normal output under cw operation as shown in the turn-on procedure (figure 2-1).

1. Rotate the AMPL. MOD. SELECTOR to OFF.
2. Rotate SWEEP SELECTOR switch to EXT.
3. Feed a signal from an external source into the FREQUENCY MOD. jack.

Note: Refer to chart figure 2-8 for upper limit on amplitude of modulating frequencies higher than 60 cps. As frequency of modulating frequency increases the band swept must be reduced.

CHARACTERISTICS -

Modulation:

A linear change in modulation voltage produces an exponential change in rf output frequency. Modulation is up and down from the FREQUENCY (KMC) dial setting.

Phase:

Positive-going voltage causes the frequency to increase.

Note: The AMPL. MOD. SELECTOR and SWEEP SELECTOR switches operate independently. Both may be set in any position at any time. Thus two types of modulation may be obtained simultaneously.

Figure 2-7. External Frequency Modulation

the bwo will be operating over a small section of the helix voltage-vs-frequency curve and the curve can be considered a straight line. If, however, large modulating voltages are used, the bwo will be operating over a large section of the helix voltage-vs-frequency curve and the curve is exponential. When the modulating voltage is large, a shaping circuit may be used which provides an exponentially-varying voltage which has a helix voltage-vs-input-voltage curve which is the same shape as that of the bwo helix voltage-vs-frequency curve.

CAUTION

The bwo can be damaged if the 683C is swept out of its rated band (2 to 4 kmc [gc]). The possibility of sweeping outside the band is greatest 1) when a wide band is swept (voltage excursions applied to the FREQ. MOD. jack are greater than 150 volts peak-to-peak) and 2) when the FREQUENCY dial is set near one edge of the band.

To guard against sweeping outside the band, the arrangement shown in figure 2-9 may be used. The output from the 683C is applied through an attenuator, two wavemeters, and a crystal detector to the vertical input of an oscilloscope. The modulating voltage is applied to the oscilloscope horizontal input. Each wavemeter is tuned for one edge of the band. Thus, as the band is swept, a wavemeter pip at each end of the oscilloscope trace will define the rated range, and any excursion beyond limits can be determined.

2-8. APPLICATION.

One of the valuable uses for a microwave sweep oscillator lies in its ability to permit rapid measurements of microwave device performance over a range of frequencies. One example is the measurement of

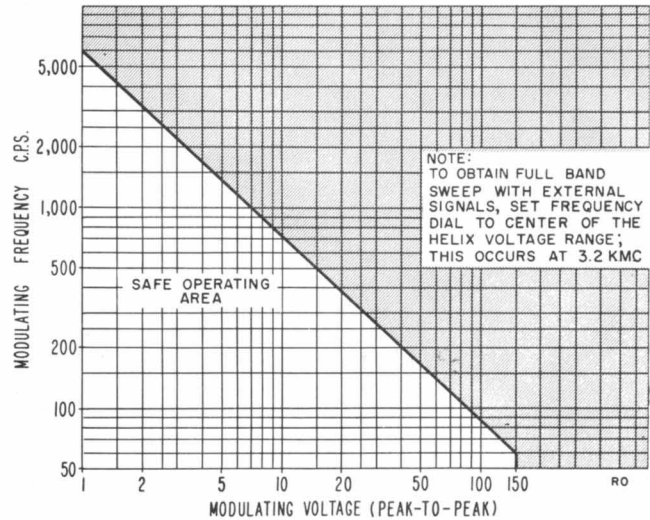

Figure 2-8. Allowable External Frequency Modulation Voltage Amplitude vs Modulation Voltage Frequency

reflection or swr with a reflectometer, but often overlooked is the fact that a reflectometer or ratio meter is equally valuable for measuring attenuation, gain, and other transfer characteristics over a wide range and in rapid fashion. The ratio meter system is also good for measuring the magnitude of scattering matrix coefficients when it is desired that a transmission-line network be described in terms of such coefficients.

Information regarding this type of measurement using the 683C is found in Hewlett-Packard Journal Sept.-Oct. 1957, Volume 9, No. 1-2 (Permanent Record and Oscilloscope Techniques with the Microwave Sweep Oscillator); Hewlett-Packard Journal Dec. 1960, Volume 12, No. 4 (Improved Sweep Frequency Techniques for Broadband Microwave Testing); Application Note 42 (Applications of the 416A Ratio Meter).

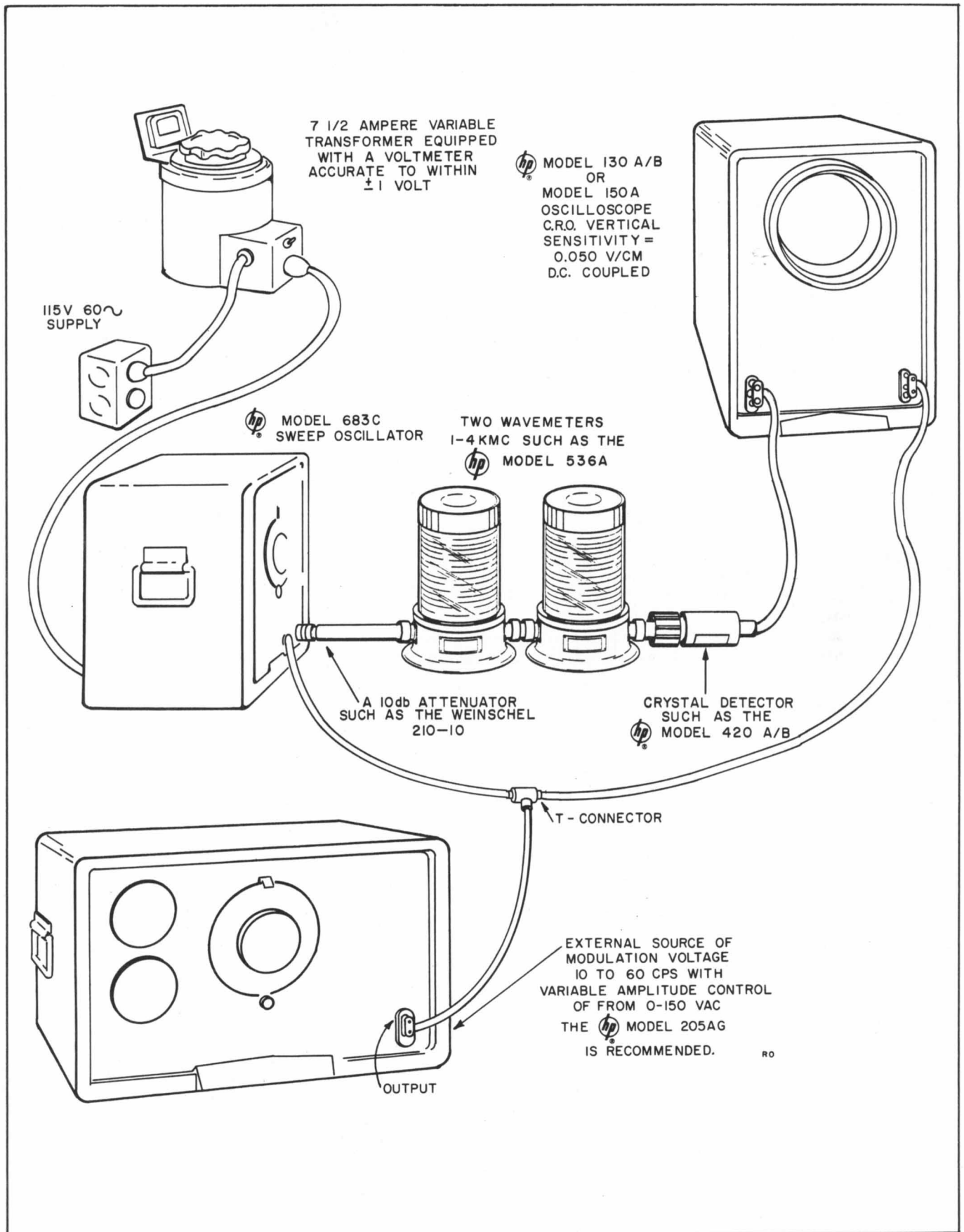
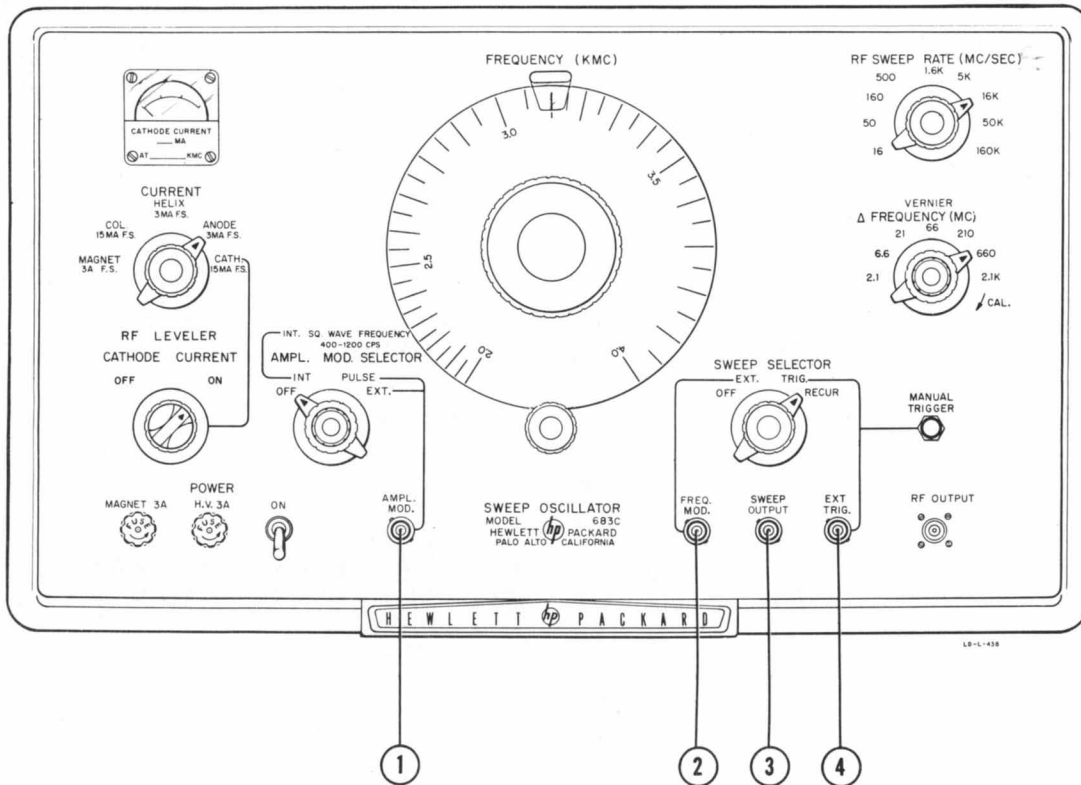

Figure 2-9. Suitable Setup for Measuring Frequency Deviation Limits when using External FM



1. PULSE

Input to AMPL. MOD. jack is ac coupled.
Input Pulse: +10 volts or more; 5 milliseconds maximum length.
Impedance: 390K shunted by 25 pf.

EXT.

Input to AMPL. MOD. jack: dc to 300 kc;
-20 volts or more reduces rf level from cw level to zero.
Impedance: 750K shunted by 25 pf, with diode CR301 biased off.

2. FREQ. MOD.

Input Impedance: ac coupled; 43K shunted by approximately 100 pf.

Frequency Response: Full band may be swept 10 cps to 60 cps, input voltage must be reduced to avoid overload of power supplies. Refer to chart figure 2-8 for limits at higher modulating frequencies.

Sensitivity: 29.2 mc/volt at 2 kmc (gc) and 8.5 mc/volt at 4 kmc (gc).

3. SWEEP OUTPUT

Output: 20-25 volts positive-slope sawtooth, concurrent with rf output.
Internal Impedance: 10K shunted by 20 pf.

4. EXT. TRIG.

Input: Positive pulse, 20 volts or more, rise time greater than 3 volts/ μ sec.
Impedance: 10K shunted by 10 pf.

Figure 2-10. Input and Output Connector Characteristics

SECTION III THEORY OF OPERATION

3-1. CONTENTS.

This section explains how the circuits of the sweep oscillator operate. First, the overall operation of the backward-wave oscillator tube is described, since the bwo tube is the heart of the instrument. Once the characteristics of the tube are understood, an overall picture of the purpose of the various circuits is more easily understood.

3-2. BACKWARD-WAVE OSCILLATOR TUBE.

The helix type backward-wave tube (figure 3-1) used in the sweep oscillator is similar in appearance to the helix type traveling wave tube. Each basically consists of an electron gun, a metallic helix through which the electron beam passes axially, and a collector electrode. The electron gun assembly in a bwo tube produces a hollow electron beam. An external solenoid is used to produce a strong, uniform, axial magnetic field around the bwo tube. This magnetic field focuses the electron beam into a hollow cylinder which is concentric with the helix. The tube is accurately positioned in the magnetic field so that the electron beam passes down the full length of the tube to the collector without striking the helix. Briefly, the tube oscillates as follows:

RF energy travels down the helix away from the collector end at a velocity equal to the speed of light multiplied by the ratio of the turn-to-turn spacing of the helix divided by the circumference of the helix. This energy causes electric fields to exist along the

helix. Since the helix is quite long, a number of rf cycles will exist along its length which speed up and slow down the electron beam, causing it to bunch. The velocity of the electron beam is slightly faster than the effective phase velocity of the rf energy along the helix. When oscillations are taking place, the bunched electron beam advances a quarter of a cycle as it approaches the collector end of the tube, and thus encounters the full decelerating effect of the electric field. This results in the electron beam giving up a maximum amount of kinetic energy to the backward traveling rf wave on the helix.

The helix used in the 683C bwo is a bifilar wound coil that produces a 100-ohm balanced output. The balanced output is sent through a balun which converts the balanced output to a 50-ohm single-ended output at the front panel.

A. OUTPUT FREQUENCY. The operating frequency of the bwo is controlled by changing the helix voltage over a range of approximately 250 to 2000 volts positive with respect to the cathode. The bwo output frequency vs helix voltage curve is exponential, with the frequency change per volt decreasing as rf output frequency increases. The frequency change per volt change at the helix varies somewhat from tube to tube, but is approximately 0.56 mc/volt at 4 kmc (gc) to 2.08 mc/volt at 2 kmc (gc).

Control of the operating conditions of the bwo thus becomes simply one of controlling the potentials supplied to the tube.

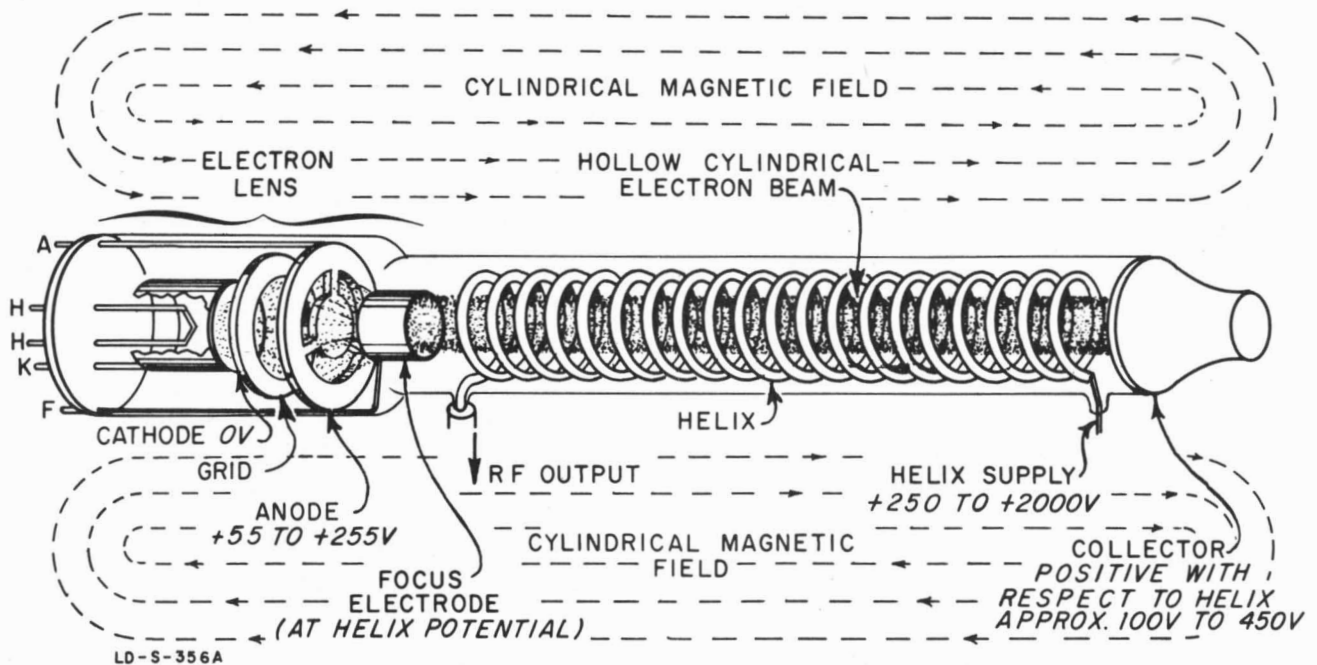

Figure 3-1. Backward-Wave Oscillator Tube Construction

B. OUTPUT POWER. The power output is determined by electron beam density, which is controlled by the cathode-to-anode voltage. The cathode is at ground, and the level of the anode voltage is determined by the setting of CATHODE CURRENT control.

C. MODULATION. The oscillator can be amplitude modulated at any percent from 0 to 100 by varying the voltage on the control grid from approximately 0 to 20 volts negative with respect to the cathode.

With pulse modulation, grid voltage under the "on" condition is essentially the same as under the cw condition, and incidental fm is negligible.

D. FACTORS AFFECTING FREQUENCY. The frequency of oscillation of the two tube is determined by the velocity of the electron beam. This in turn is determined by the voltage difference between the cathode and the focus electrode. The frequency of oscillation is also affected by the anode voltage and the magnetic field flux density. Frequency will change with anode voltage at a rate of approximately 350 kc/volt change.

The change in frequency due to changes in the magnetic field is essentially constant at any operating frequency. With the solenoid used in this instrument, a one-volt change across the solenoid winding will cause a change in frequency of 50 kc. However, the supply to the magnet is very well regulated so that regulation and ripple are held to very low levels. This effectively eliminates the solenoid supply as a source of frequency change.

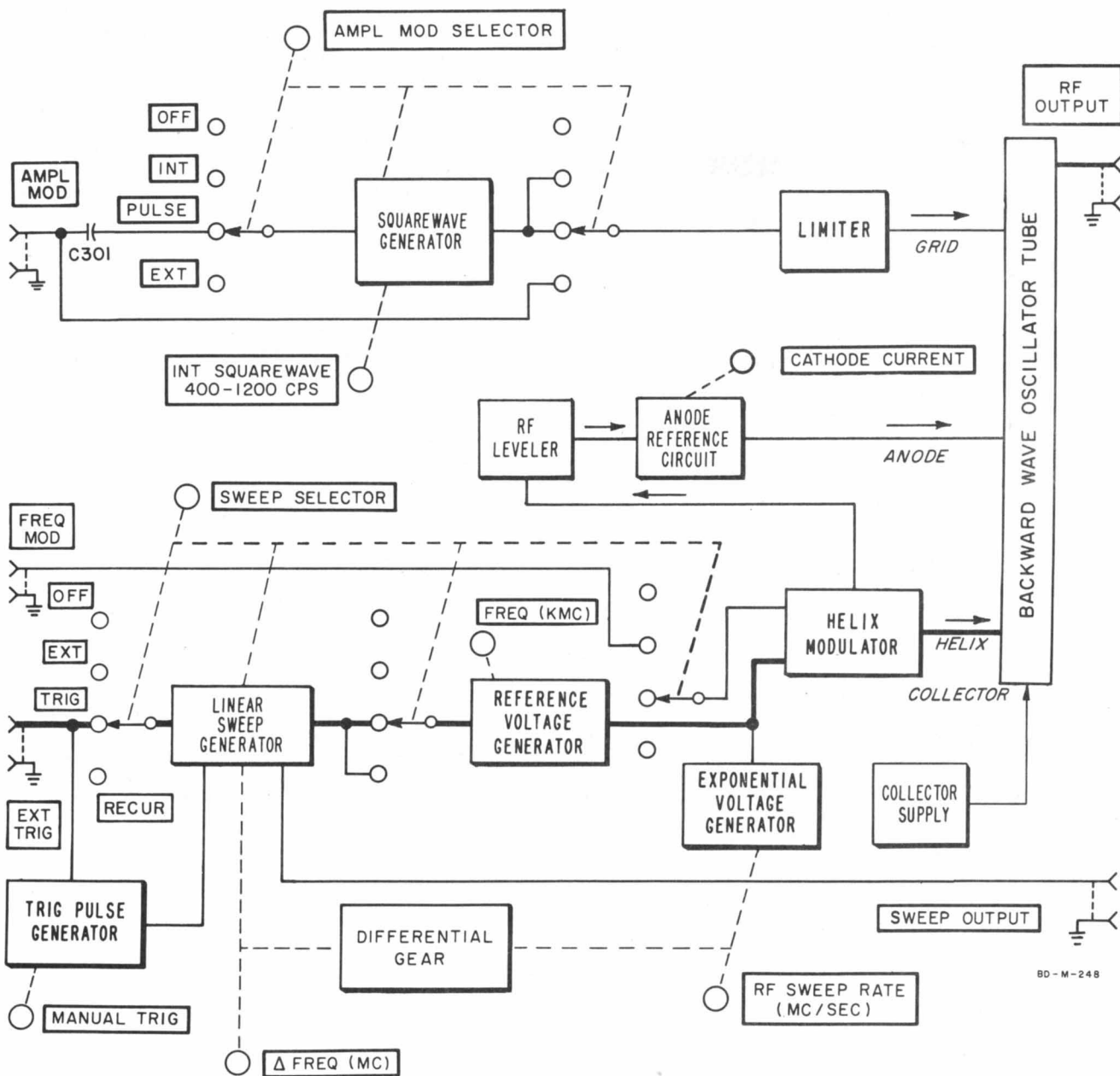

Figure 3-2. Block Diagram Model 683C Sweep Oscillator

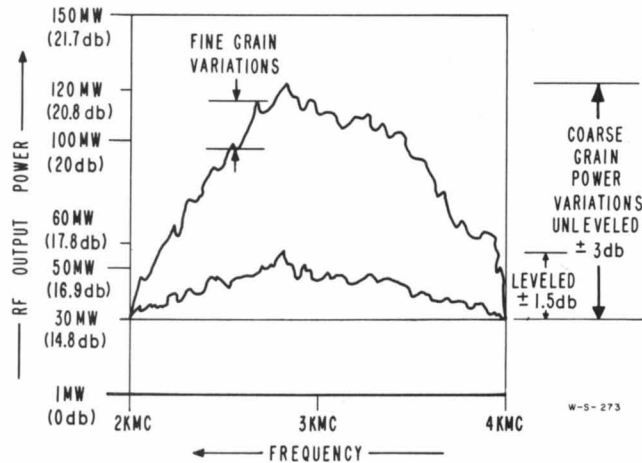

Figure 3-3. RF Leveler Detected Waveform (Leveled and Unleveled Positions)

3-3. RF LEVELER AND ANODE REFERENCE CIRCUIT.

A. GENERAL. The leveler circuit is an internal device which reduces power variations across the band to ± 1.5 db or less. Leveling action is accomplished by programming the anode voltage to compensate for the coarse grain power variation characteristics (figure 3-3) of the bwo tube.

The leveler circuit functions in both the cw and recurring sweep modes of operation. In the RECUR position the leveler circuit compensates for coarse grain power variations throughout the frequency range (2 to 4 kmc [gc]). In cw operation the leveler circuit holds the output power level relatively constant for each selected output frequency. To describe sweep operation, swept anode voltage, the leveler circuit will be discussed with the SWEEP SELECTOR switch in the RECUR position and with the full band being swept.

The bwo output frequency and power level are both voltage controlled. For a linear change in output frequency, an exponential voltage is applied to the helix. Simultaneously, the Δ voltage proportional to the helix exponential (figure 3-4A) is sent through the leveler circuit, reshaped, and applied to the bwo anode (figure 3-2). The anode voltage waveform is composed of four variable segments. Segments 1 and 2 (figure 3-4B) are shaped by cathode follower V303A and associated circuitry. Segments 3 and 4 (figure 3-4C) are shaped by inverter amplifier V302A and associated circuitry. The four segments are combined at the junction of CR302 and CR303 (figure 3-4D). The resultant waveform is then applied through reference amplifier V302B and cathode follower V303B to the bwo anode.

B. ANODE WAVEFORM. A voltage proportional to the helix voltage is taken from the cathodes of differential amplifier modulator V105, and applied through R321 (segment 1 adj., figure 3-5) to the grid of cathode follower V303A. Potentiometer R321, by varying the amount of signal to V303A, determines the slope of segment 1 (see figure 3-4B). The wave-

form of segment 1 (taken from the cathode of V303A) is an exponentially decaying voltage which starts at +150 volts. At a point determined by the setting of R324 (segment 2 adj., figure 3-5) diode CR302 opens (ceases conducting) causing a plateau in the waveform. This plateau is segment 2 (see figure 3-4B). Crystal diode CR302 remains open for the duration of the sweep.

While segments 1 and 2 are being formed, the exponential voltage at the cathode of differential amplifier V105 is applied to the grid of V302A through the potentiometer R315 (segment 3 adj., figure 3-5). As CR303 is open, no output from V303A appears at the junction of CR302 and CR303. At a time determined by the bias on CR303, the positive-going voltage on the plate of V302A causes CR303 to close. The rising voltage at the junction of CR302 and CR303 is segment 3 (figure 3-4C). The slope of segment 3 is determined by the setting of R315 (segment 3 adj., figure 3-5). The cathode of V302A follows the negative-going voltage applied to the grid of V302A. At a time determined by the voltage at the arm of the potentiometer R320 (segment 4 adj., figure 3-5), CR304 will conduct, effectively decreasing the cathode resistance of V302A and increasing the gain of the circuit. This increased gain accounts for segment 4 (figure 3-4C).

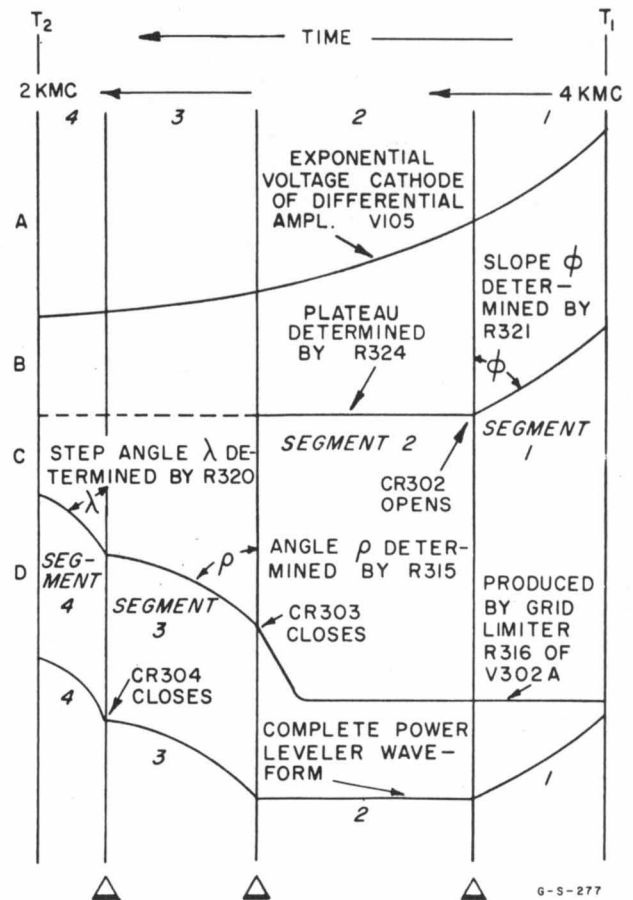

NOTE:
△ THE POINTS AT WHICH THE SEGMENTS MEET, MOVE BOTH HORIZONTALLY AND VERTICALLY.

Figure 3-4. Adjustable Segments of Compensated Helix Voltage

The composite waveform (figure 3-4D) at the junction of CR302 and CR303 is applied to reference amplifier V302B.

C. REFERENCE AMPLIFIER V302B AND CATHODE FOLLOWER V303B. Characteristically, anode voltage vs power level (30 mw) is different from one tube to another. Thus to obtain the power level (30 mw) specified by the two tube manufacturer, the reference anode voltage must be variable. The purpose of the reference amplifier, V302B, is to supply a variable dc reference voltage between +55 and +255 volts at the two anode.

Resistor R327 is a front panel control (CATHODE CURRENT) that varies the two output power from 0 to 100%. The waveform at the plate of V302B is dc coupled to the grid of the cathode follower V303B which in turn applies the complete waveform to the two anode. Degenerative feedback from the cathode of V303B is applied to the grid of V302B through R330 to reduce drift caused by tube aging and line voltage variations.

D. RF LEVELER OFF POSITION. When RF LEVELER switch S302 is in the OFF position, the cathode of V302B is placed at a dc reference by the combined settings of R327, R332, and R335. The purpose of the RF LEVELER OFF position is to make available at certain frequencies higher power outputs. Since rf leveling action is referenced at the low power point, power output is sacrificed to obtain the desired leveling action.

3-4. AMPLITUDE MODULATOR.

Signals for amplitude-modulating the rf power are applied to the control grid of the two tube, through the amplitude modulator circuit. Voltage from the internal 400- to 1200-cps square-wave generator or signals (pulse, square wave, sine wave, or complex wave) from an external source may be used to modulate the rf output. Condition of the amplitude modulator circuit under various types of operation is discussed briefly below.

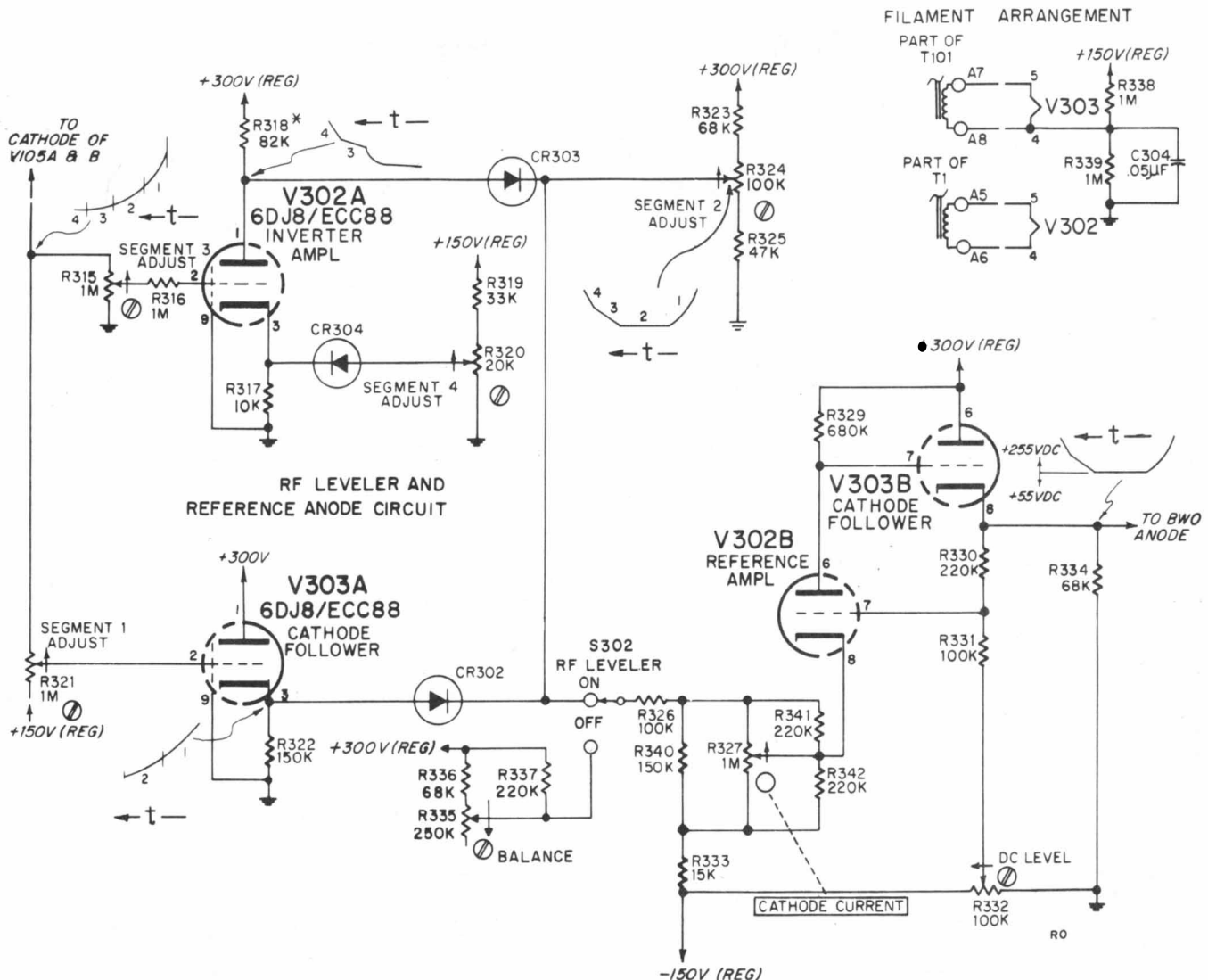

Figure 3-5. RF Leveler Circuit

A. CW OPERATION. In cw operation (AMPL. MOD. SELECTOR at OFF) diode CR301 clamps the bwo control grid to ground. The rf output level is determined by the voltage on the anode, which is adjusted by means of the CATHODE CURRENT control.

B. INTERNAL SQUARE-WAVE OPERATION. With the AMPL. MOD. SELECTOR on INT dual triode V301 operates as a symmetrical free-running multi-vibrator. The frequency of the square wave is determined by the charge and discharge time of C302 and series-connected R303 and R302 (INT. SQ. WAVE FREQUENCY control). The symmetry of the square wave is set by adjusting (with R310) the dc bias on the B section of V301. The two adjustments are slightly interdependent. The square-wave amplitude is clamped to ground through crystal diode CR301. Thus the level of the rf output during the "on" portion of the square-wave cycle corresponds to the cw level, set by the CATHODE CURRENT control.

C. PULSE OPERATION. With the AMPL. MOD. SELECTOR switch on PULSE, the AMPL. MOD. jack is connected, through capacitor C301, to the grid of the A section of V301. Dual triode V301, with diode CR301 in the plate circuit of its B section, is operated as a limiting amplifier to provide constant amplitude pulses to the control grid of the bwo tube. The A section of V301 is operated as a cathode follower and the B section as a single-stage amplifier. Before an externally-supplied pulse is received, the B section of V301 is conducting. The B-section plate, through contacts on the AMPL. MOD. SELECTOR switch, is tied to the control grid of the bwo tube; both are tied to the anode of diode CR301. With V301B conducting, the bwo tube is cut off. The incoming positive pulse, coupled by capacitor C301 to the V301A grid, is coupled to the V301 cathode, and turns off the B section. The B-section plate rises, and is clamped to ground through diode CR301. Thus during the "on" time of the pulse, the level of the bwo rf output corresponds to the cw level (set by the CATHODE CURRENT control).

The PULSE position is intended primarily for applications where low voltage pulses are available. Pulses of 20 volts or more can be used on EXT. position for faster pulsing characteristics (see below).

D. EXTERNAL AM OPERATION. With the AMPL. MOD. SELECTOR in the EXT. position the 300-volt source is removed (see figure 3-6), eliminating bias current to diode CR301. The grid of the bwo tube is returned through a 1-megohm resistor R312 to ground (figure 3-6) which permits application of positive input pulses provided they are either capacitively coupled or superimposed on an externally supplied -20 volt bias. The coupling capacitor must be sufficiently large and the duty cycle such, so as to maintain a charge (grid bias) between modulation pulses.

Generally the external modulation facility is used for very fast rise time pulse modulation. Amplitude modulating the bwo tube with a sine wave is also possible but introduces frequency pulling.

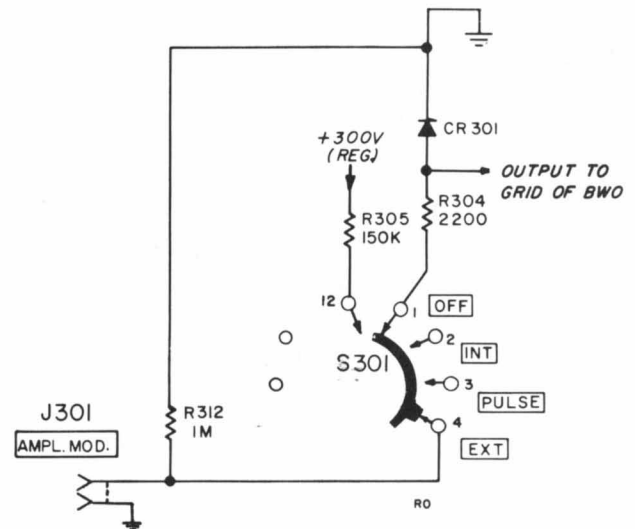

Figure 3-6. Amplitude Modulation EXT. Position

3-5. HELIX MODULATOR.

The helix modulator (figure 4-22) consists of three major sections: the linear sweep generator, the helix supply reference voltage generator, and the exponential voltage generator. The linear sweep generator generates: 1) a precision time interval to start and stop the exponential voltage generator thus determining the time duration of the rf output sweep, and 2) a linear sweep output voltage concurrent with the rf output sweep. The length of the precision time interval is governed by the settings of both the Δ FREQUENCY and the RF SWEEP RATE controls.

The helix supply reference voltage generator determines the rf output frequency for cw operation and the starting frequency for swept operation. The output of the reference voltage generator is continuously adjustable by means of the FREQUENCY (KMC) dial which controls the setting of variable resistor R236 in the cathode circuit of control tube V207A. The reference voltage generator determines frequency by supplying the reference voltage for the regulated helix supply and the regulated dc voltage for the exponential voltage generator.

The exponential voltage generator produces an exponentially-varying voltage to drive the bwo helix for internal sweep operation. Since the voltage-vs-time curve of the exponential generator is essentially the same shape as that of the bwo helix voltage-vs-frequency characteristic, the bwo produces a linear rf output sweep.

3-6. LINEAR SWEEP GENERATOR.

The linear sweep generator consists of a Miller feedback integrator (V204A) which generates a linear voltage sweep whose slope can be adjusted by changing the charging rate of the integrator capacitor (C207 to C213). The Δ FREQUENCY (MC) range switch (part of which is shown in figures 3-8 and 4-26) changes the values of the integrator resistors (R230 to R232) and capacitors (C207 to C213) to obtain step changes

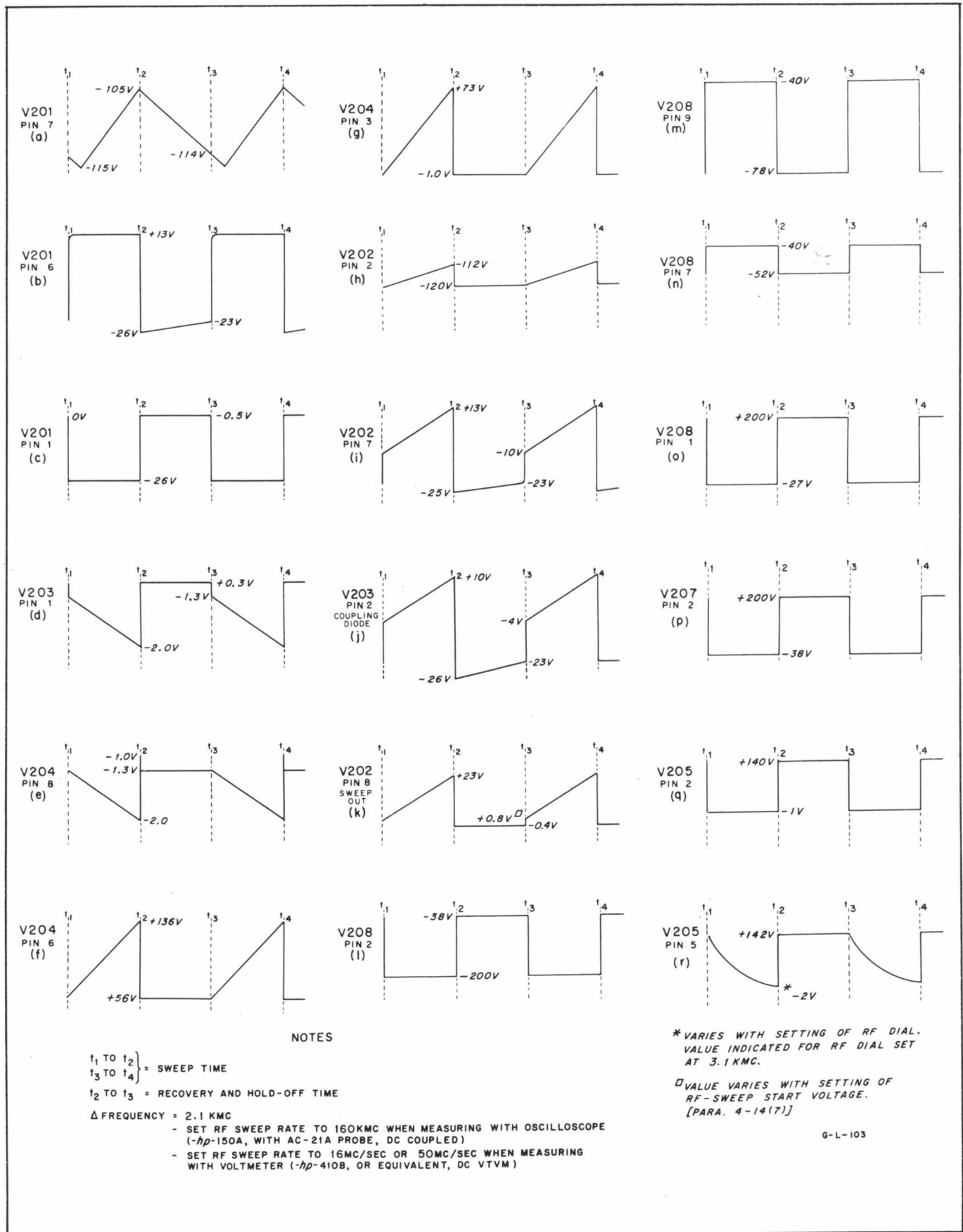

Figure 3-7. Frequency Modulator Waveforms

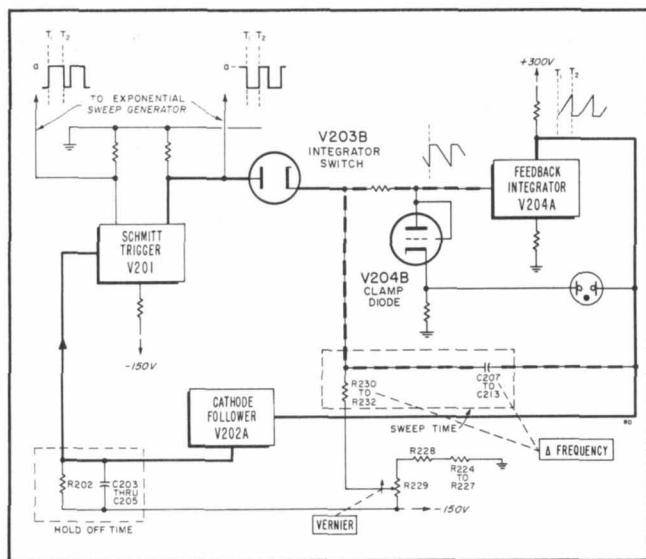

Figure 3-8. Simplified Schematic of Sweep Circuit

in slope, while the vernier (R229) on the ΔFREQUENCY (MC) switch varies the capacitor-charging voltage to provide slope adjustment between steps. The feedback integrator is started and stopped by schmitt trigger V201 which shunts the integration circuit to ground through integrator switch V203B to prevent sweeping, and releases it from ground to start a sweep.

The feedback integrator is made automatically recurrent, and the output is made constant in amplitude by operating the schmitt trigger (see figures 3-8 and 4-26) from the output of the integrator. After being unlocked by the schmitt trigger, the integrating circuit charges to a predetermined level established by the sensitivity of the trigger. At this level, the feedback voltage causes the trigger to change state. The trigger relocks the integrator circuit and terminates the sweep with a rapid flyback. Trigger tube V201A is held conducting for a predetermined period of time by a charge on C205 and supplementary capacitors to allow time for circuit recovery. As the capacitors discharge, trigger V201 returns to its original state which, in turn, unlocks the integrator circuit so it can generate another sweep.

When the SWEEP SELECTOR (S202) is set to TRIG., schmitt trigger V201 is biased by voltage divider R204 and R205 to hold the A side conducting. Thus it does not retrigger, except upon receipt of an externally-generated positive pulse or a pulse provided by the front panel pushbutton (S201, MANUAL TRIGGER). The positive pulse instantaneously raises the voltage on pin 6 (V201) to almost zero volts. This positive-going pulse is transferred to pin 2 causing the B side to conduct which, in turn, cuts off the A side.

With the SWEEP SELECTOR switch set to RECUR, V201A conducts before a sweep starts because its grid is held positive by the charge on capacitor C205 placed there by cathode follower V202A when the previous sawtooth went positive. In this state, the A-side plate voltage and B-side grid voltage are down,

while the B-side plate voltage is up. With the V201B plate voltage up, integrator switch V203B conducts and locks the integrator circuits to ground through R208. As the charge on C205 leaks off through R202, the A-side grid voltage reaches a point (t_1 figure 3-7a) where it causes the A side of the schmitt trigger to cut off and the B side to conduct.

At this time, V201 A-side's plate voltage and B-side's grid voltage go up, and B-side's plate voltage goes down, cutting off (opening) integrator switch V203B. Opening the switch permits the grid of the feedback integrator and one side of the integrator capacitor (C207 through C213) to charge through one of the resistors (R230 to R232) to a negative voltage determined by the setting of R229. As the capacitor charges negatively, the voltage at the grid of V204A falls (figure 3-7e). The plate voltage rises approximately 10 volts for each 0.1 volt the grid falls (100 being the approximate gain of this state). The integrator tube (V204A), by virtue of this gain and the degenerative feedback due to the integrator capacitor connected between its plate and grid, has a small grid-voltage change for a large plate voltage change (see figure 3-7f). Since the resistor connected to the grid of V204A is returned to -50 volts or greater and the grid voltage only changes about 0.7 volt (plate voltage change of approximately 80 volts) the current through the resistor is nearly constant. Therefore integrator tube V204A, by means of its gain, allows the integrator capacitor to charge to a large voltage while maintaining a nearly constant charging current. The change in voltage across C213 thus rises at a linear rate.

As the plate of V204A rises during integration, it reaches a level (t_2 figure 3-7f) where the voltage coupled through cathode follower V202A to schmitt trigger V201 (t_2 figure 3-7a) switches the V201 B-side plate up, locking the integrator grid to ground and stopping the integration process. Upon being stopped, the integrator plate voltage drops rapidly from its high positive voltage. The plate voltage is coupled through a 63-volt constant-voltage neon lamp and diode clamp (triode V204B connected as a diode) back to the integrator grid. As the integrator plate drops, V204B's cathode drops (figure 3-7g). When V204B's cathode voltage drops to -1.0 volt, V204B's plate voltage is -1.3 volts (due to contact potential). The integrator grid is clamped at approximately -1.3 volts and the circuit stabilizes. During integration, diode V204B is cut off (opened) as its plate is carried negatively when integrator switch V203B releases the circuit from ground (figure 3-7e). This removes the clamp circuit and allows the grid of V204A to go in a negative direction.

The length of time that the schmitt trigger A side is held conducting to allow for circuit recovery is determined by the positive charge placed on C205 by V202A. For the longer sweep times, the ΔFREQUENCY switch S203, adds additional capacity to C205 to lengthen the discharge time.

The linear sweep voltage from the feedback integrator plate is coupled by output cathode follower V202B to the SWEEP OUTPUT connector. Two other signals are coupled to the grid of V202B. First, a negative voltage from the plate of V201A is coupled through

diode V203A to cut off V202B during the fly-back time and at all times before a sweep starts (see figure 3-7j). Second, a dc voltage is applied and adjusted by R217 which will give an instantaneous +1.5 volt output from J203 when schmitt trigger V201 flips and opens coupling diode V203A removing the negative bias on the grid of V202B (see figure 3-7k). The instantaneous initial positive output voltage produces a thin section of trace on the cathode ray tube which separates the beginning of the main trace from the bright dot, or vertical line, which occurs during circuit recovery time.

3-7. HELIX SUPPLY REFERENCE VOLTAGE AND EXPONENTIAL VOLTAGE GENERATORS.

The frequency of the rf output of the sweep oscillator is determined by the amplitude of the voltage applied to the bwo helix. The amplitude of the helix voltage is varied by varying the reference voltage supplied to the regulated helix supply (figure 4-22). For cw operation, the reference voltage, supplied by the reference voltage generator, has a constant amplitude, the level being set by means of the FREQUENCY (KMC) dial. For sweep operation, the reference voltage is supplied by the exponential voltage generator. The amplitude of this voltage starts at a value established by the setting of the FREQUENCY (KMC) dial, and then decreases exponentially. The resulting output is a linear rf sweep, the bwo being an exponential-law device. Operation of the reference and exponential voltage generators are briefly described below.

A. REFERENCE VOLTAGE GENERATOR. Basically, the reference voltage generator (figures 3-9 and 4-26) is a typical voltage regulator with a source of reference voltage (regulator tube V206), a control tube (V207A) which compares the reference voltage with a sample of the reference voltage generator output, and a series regulator (V207B). A signal from the control tube controls conduction through the series regulator in such manner that any tendency of the output to deviate from the desired level is compensated for.

The output of V207B is brought through regulator switch V205A and applied 1) to differential amplifier V105 in the regulated helix supply (figure 4-22) and capacitor C215 (in the line to V105), and 2) to the grid of control tube V207A to provide the sample of output voltage required by the regulator. Status of tubes during cw operation is shown in table 3-1.

However, the reference voltage generator's output level can be varied from the front panel providing the means for selecting the frequency of the rf output. In addition, it is possible to electronically turn off the reference voltage generator and to turn it on again after precise predetermined time intervals required for sweep operation. The circuit sequences which effect this action are described in subparagraph B.

B. EXPONENTIAL VOLTAGE GENERATOR. Operation of the exponential voltage generator requires all the circuits shown in figures 3-9 and 4-26. Current for charging the capacitance in the rc circuit

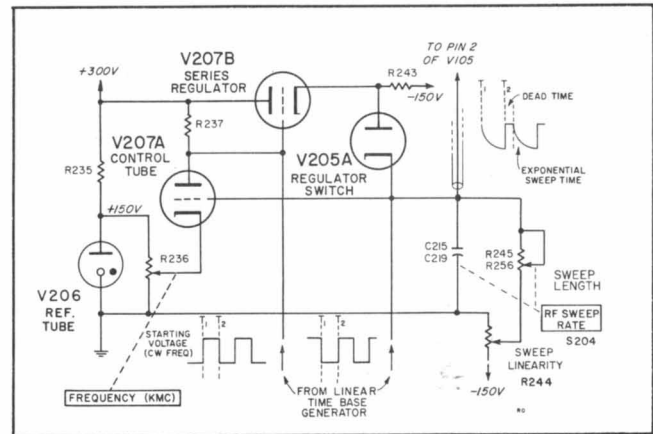

Figure 3-9. Simplified Schematic of Exponential Sweep Circuit

of the exponential voltage generator is supplied by the reference voltage generator. As soon as the reference voltage generator is turned off, the charged capacitor(s) starts to discharge through its corresponding resistor network, and it is this exponentially decaying voltage which is fed to the regulated helix supply. Turn-off of the reference voltage generator (as well as its turn-on after a precise predetermined time) is under the control of the linear sweep time generator. The rate at which the capacitor discharges (and thus the rate at which the rf frequency is changing) is determined by the values of capacitance and resistance selected by the RF SWEEP RATE (MC/SEC) switch, S204. The exponential voltage generator is turned off when the reference voltage generator is again turned on by the linear sweep time circuit. How long the voltage is permitted to decay is thus determined by the linear sweep time circuit which is controlled by Δ FREQUENCY (MC) switch S203. Thus the width of band swept (band "distance") (sweep time x sweep rate) is determined by the settings of both S203 and S204. (The Δ FREQUENCY switch determines time though it is calibrated in terms of "distance".) Circuit action is discussed in more detail below.

In the following discussion of circuit action the term "sweep" refers to the sawtooth voltage produced by the linear sweep time generator; the term "rf sweep" refers to the output of the bwo tube (figure 4-21). Operation of the linear sweep time generator is described in paragraph 3-6, and only that part of the action which is pertinent to an understanding of the exponential voltage generator will be discussed here. Condition of main tubes at various stages of circuit action is shown in table 3-1.

With the instrument set for internal sweep operation, the linear sweep time generator is producing a sawtooth voltage. While the voltage at the output of feedback integrator V204A is rising, the A section of schmitt trigger V201 is cut off and the B section is conducting. Feedback from V204A is returned to the grid of V201A, and when the amplitude of the sawtooth reaches the schmitt trigger upper hysteresis limit, V201 changes state: the A section starts to conduct and the B section cuts off. The feedback also charges

Table 3-1. Condition of Tubes During CW and RF Sweep

Operation	State of Circuit	V201A	V201B	V208A	V208B	V207A	V207B	V205A	V205B
CW		Cond.	C. O.	C. O.	Cond.	Cond.	Cond.	Cond.	C. O.
RF Sweep	Before rf sweep starts; Exp Gen capacitors charging	Cond.	C. O.	C. O.	Cond.	Cond.	Cond.	Cond.	C. O.
	RF sweep starts; Ref Volts Gen turned off	C. O.	Cond.	Cond.	C. O.	C. O.	C. O.	C. O.	Cond.
	RF sweep reaches low end: schmitt trigger trips or decaying voltage reaches -1.1 volt	Cond.	C. O.	C. O.	Cond.	Cond.	Cond.	Cond.	C. O.
		C. O.	Cond.	Cond.	C. O.	C. O.	C. O.	Cond.	Cond.
Cond. = conducting					C. O. = cut off				

capacitor C205 in the V201A grid circuit, and this charge holds V201A conducting during the sawtooth dead time.

With V201A conducting there is a positive signal on the grid of V207B, supplied through V208A; this holds series regulator V207B in conduction. With V201B cut off, the cathode of regulator switch V205A is pulled in a negative direction, holding V205A in conduction. In the same manner as in cw operation, current through V207B, diode CR204, and V205A establishes the charge on capacitor C215 at a level which corresponds to the setting of the FREQUENCY (KMC) dial.

During the sawtooth dead time, the charge on capacitor C205 leaks off through resistor R202. When the voltage across C205 drops to the schmitt trigger lower hysteresis limit, V201 again changes state: V201A cuts off and V201B turns on. This results in a negative signal on the V207B grid, cutting off conduction through the series regulator which 1) opens regulator switch V205A and 2) closes clamp V205B. With supply voltage removed, capacitor C215 starts to discharge through the resistors selected by the RF SWEEP RATE switch. Thus the voltage applied to V105 in the regulated helix supply starts to fall exponentially, causing the frequency of the rf sweep to change at the rate selected by the RF SWEEP RATE switch. The rc network discharges toward the potential on the slider of variable resistor R244, the rf sweep linearity adjustment.

In the usual case the voltage decay will continue until the amplitude of the sawtooth voltage again reaches the schmitt trigger upper hysteresis level, and conducting V201A turns on the reference voltage generator. To protect the two tube, however, circuitry is included to prevent the voltage from decaying to too low a level. The clamp V205B, when conducting, holds the plate of V205A at approximately -1.1 volts. If the linear sweep time generator does not turn on the reference voltage generator before the exponential voltage decays to approximately -1.1 volts, V205A will start to conduct and will clamp the exponentially-decaying voltage to -1.1 volts.

Thus the length of time the voltage decay is permitted to continue (unless it reaches -1.1 volts first) is determined by how long the A section of schmitt trigger V201 (and therefore the reference voltage generator) is cut off. This period is the time required for the amplitude of the sawtooth to reach its maximum positive value. This total time is determined by components switched into the linear sweep time generator circuit by the ΔFREQUENCY switch (S203).

The voltage at the center tap of potentiometer R236 is established by current distributed through resistors R233, R234, R263, R240, diode CR202, and the A section of V201. In cw operation (V201A conducting), diode CR202 is forward-biased and the junction of R233 and R263 is practically at ground, CR202 clamps the junction of R233 and R263 so it cannot go negative. Resistor R263 establishes the voltage at the cathode of coupling diode V203A at such level that V203A will not close until V201A starts to conduct (when the sawtooth reaches maximum level and the flyback starts). Tap resistors R234 and R240 change the voltage characteristic of the V207A cathode circuit in such manner that dial calibration is improved (crowding at the low-frequency end is reduced).

Diode CR204 is a 55-volt breakdown diode which maintains a 55-volt difference in potential between the cathode of V207B and the plate of V205A.

Front panel controls ΔFREQUENCY (MC), S203, and RF SWEEP RATE (MC/SEC), S204, are operated through differential gears, and are so arranged that a combination which would require a sweep time of less than 0.0135 second is prevented. Thus, though the ΔFREQUENCY selector is the control for switch S203, the ΔFREQUENCY selector will also operate switch S204 if the RF SWEEP RATE selector is set for too high a rate for the sweep band selected. In the same manner, the RF SWEEP RATE selector will operate switch S203 if the ΔFREQUENCY switch is set for too short a sweep time (too narrow a frequency band) for the sweep rate selected.

3-8. REGULATED POWER SUPPLIES.

In addition to the magnet regulated power supply, there are five regulated voltages generated in the 683C: 1) the regulated -150 volt supply which is not dependent upon any other supply but affects all other supplies, 2) the regulated, +300 volt supply which depends upon the -150 volt supply for a reference voltage, 3) the regulated helix supply which depends upon both the -150 volt and +300 volt supplies, 4) the collector supply which depends upon the regulated helix supply to determine its output voltage, and 5) a reference voltage supply (helix supply reference voltage generator) in the frequency modulator, which provides a reference for the regulated helix supply. The regulators are fed by half-wave silicon rectifiers powered from a single power transformer, T101.

The sequence of operation upon applying line power to the 683C and the operation of the helix overload relay are explained on the magnet power supply voltage and resistance diagram (figure 4-15).

The operation of all the voltage regulators is similar, so only the operation of the -150 volt regulator is explained.

A. -150 VOLT REGULATED POWER SUPPLY. In the -150 volt regulated supply (figure 4-21), CR105 and CR106 are half-wave rectifiers which supply approximately 420 volts to the regulator series tube, V107B. Since the output voltage is negative with respect to ground the cathode of V107B is grounded. The grid-to-cathode voltage of V107B is adjusted to class A operating conditions, and the tube acts like a variable resistor which adjusts its resistance to maintain a constant voltage on the -150 volt bus. Thus at normal line voltage, the tube has approximately 270 volts drop from plate to cathode.

V108, a glow discharge reference tube, maintains a constant voltage difference between -150 volts and the grid of the differential amplifier control tube, V109. The cathode of the triode section will maintain a constant 1-volt difference with the grid potential and thus keeps a constant 89-volt difference between the -150 volt bus and the cathode of the pentode section. Voltage divider R147, R148, and R149 provides the proper fraction of the -150 volts for the control grid of the pentode section. R148 adjusts the exact value of the bias so that the voltage at the grid of series tube V107B is held at the correct value. If the -150 volt bus tries to increase toward -151 volts, the increase will also make the control grid (pin 2) of V109 go in a positive direction with respect to the cathode. (The cathode is held at a constant voltage with respect to the -150 volt bus by the reference tube, V108, and the cathode follower triode section in V109.) The positive-going grid (pin 2) causes increased plate current to flow through the pentode section and R146. This causes increased voltage drop across R146 which lowers the grid voltage on V107B. The increased resistance of V107B brings the bus voltage back toward -150 volts. If the -150 volt level tends to decrease, the process is the same but in the reverse direction.

C123 is a coupling capacitor which couples ac ripple directly to the grid of the control tube which in turn acts to regulate it out of the output in the same manner as a dc change. This results in very low values of ripple voltage in the regulated output.

B. +300 VOLT REGULATED SUPPLY. The 300-volt supply circuit is similar to that of the -150 volt supply except it is referenced to -150 volts and includes a ripple compensating voltage divider (R137 and R138) from the unregulated output to ground. The voltage tap-off from the divider is applied to the screen grid of V107A (see figure 4-22). Compensating action of this arrangement is described below.

C. REGULATED HELIX SUPPLY. Screen voltage for control tube V103 in the regulated helix supply also is supplied from its unregulated source, through dividers R115-R119. With this arrangement of the control tube screen circuit, there is improved regulation for changes in line voltage. Circuit action is similar to that which occurs with a changing voltage on the grid of the control tube: a change in screen voltage results in a change in conduction through the tube in such direction that a change in line voltage will be compensated for by the series regulator. The result is an extremely constant output voltage regulation over the range of 103 to 127 volts line voltage. In addition, ripple voltage in the unregulated source drives the screen in the proper direction to help regulate ripple out of the output, further reducing the ripple level.

Operation of the regulated helix supply is similar to that of the low voltage supplies. However, it is more elaborate due to the extreme range of voltage control necessary, and because modulating voltages must be introduced. The voltage control tubes, V101 and V102 (series regulators), require the single-ended amplifier, V103, driven by a differential amplifier, V105, which serves two other purposes 1) the exponential helix waveform is taken at the cathode of V105 and applied to the rf leveler circuit 2) externally-supplied modulation voltages from the FREQ. MOD. jack are fed to the grid of V105 to vary the helix voltage, thus varying the frequency. Since two different helix modulating signals must also be applied to the voltage regulator, and since a greater order of regulation is necessary for helix operation, two stages of voltage amplification are used to obtain greater gain and bandwidth.

The reference voltage for the regulated helix supply is obtained from the helix supply reference voltage generator in the frequency modulator, and is applied to one side of differential amplifier V105. A sample voltage from the regulated helix supply output and a calibrating voltage obtained from voltage divider stick R132, R133, R134, and R135 are fed to the other grid of the differential amplifier. The calibrating voltage divider stick contains potentiometers which set the upper and lower helix voltage limits and, in turn, the upper and lower rf output frequency limits. The sweep voltages, which produce the rf swept output, are controlled exponential decays in the regulated reference voltage obtained from the frequency modulator.

The sample voltage from the regulator output is fed through a frequency-compensated divider composed of R122, 154, 150, 151, C114, and R131 through R135, C116, C117. Coupling from the plates of differential amplifier V105 to voltage control tube V103 is through divider V110, R128, R127 to obtain the correct dc voltage level for the grid of V103. All of these compensated coupling networks and the frequency-compensation network in the cathode circuit of V103 serve to control the gain in each step of the regulator feedback loop in such a manner that the internal impedance of the supply remains constant at 12 ohms over the required frequency range.

The collector supply is composed of two series regulator tubes, V102A and B in series, controlled by voltages from a divider powered by the regulated helix voltage. The purpose of the collector series regulators is to keep the voltage between the collector and helix within acceptable limits. Two tubes are required in series to handle the maximum voltage that can occur, which is about 1800 volts.

3-9. MAGNET CURRENT SUPPLY (REGULATED).

The backward-wave tube requires a powerful axial magnetic field to hold its hollow electron beam in focus throughout the full length of the helix. The magnetic field must be ripple-free and very constant. To this end, the magnet power supply is current regulated and maintains an exact magnetic field in spite of line voltage variations and temperature variations which change the dc resistance of the solenoid. To accomplish current regulation, a two-stage differential amplifier senses a voltage which is proportional to the magnet current and compares it against a stable reference voltage. The differential amplifier, upon sensing any change in the magnet current, controls the internal resistance of tubes in series with the magnet, and holds the magnet current constant.

V1 and V2 (figure 4-20) are the series regulators (resistances), while V4 and V5 is a two-state differential amplifier which senses any change in the voltage drop across voltage divider stick R29, R30, R31. V3, operated from its own dc power source, provides a stable dc reference voltage against which the sampled voltage is compared. Resistors shunting the series regulators serve to carry a portion of the 0.7 ampere

required by the magnet. Grids of the series regulators have parasitic suppressor resistors while the cathodes have current equalizing resistors.

The dc for the magnet supply is obtained from a voltage-doubler circuit which operates directly from the power line. One wire of the power source is connected in series with one of the filament windings of T101. This winding is poled so that it adds 6 volts to the supply voltage going to the silicon rectifier voltage doubler.

When the instrument is connected for 230-volt operation, the voltage doubler is supplied with 115 volts from one half of the primary of power transformer T1 which is acting as a 2:1 autotransformer. The fan motor and the high-voltage transformer are operated from the other half of the transformer to minimize the unbalanced load on the two halves of the primary winding.

WARNING

Be extremely careful when working in the magnet power-supply section since many tube socket terminals, filter electrolytic capacitor terminals and cans, etc. are directly connected to the power line. The instrument chassis is grounded through the NEMA three-prong connector. An accidental short caused by a test probe etc. will cause a direct short circuit on the power line. The high fault currents that will flow, before the instrument fuses can blow, may severely damage the instrument. The magnet supply ground is floating and is not related to any other ground in the instrument.

This voltage-doubler circuit is used to eliminate an additional bulky power transformer. The magnet circuitry is separate from the rest of the instrument, and the parts layout is such that a minimum number of points which are connected to the power line are exposed. The polarities of the grounded and ungrounded power conductors have been carefully controlled. If the instrument is used with a properly connected three-prong grounded receptacle, polarity will be maintained as intended. For this reason, it is recommended that a three-prong to two-prong adapter not be used with this instrument.

SECTION IV

MAINTENANCE

4-1. GENERAL.

This section contains information on the maintenance and repair of the sweep oscillator.

A suggested quick-check procedure is given for verifying that the instrument is operating properly. This check is made with the instrument in its cabinet. The procedure is useful where a routine maintenance schedule is set up to verify instrument performance, where incoming quality control checks instrument operation, or where the operator wishes to quickly satisfy himself that the instrument is operating normally and is meeting published specifications.

A troubleshooting chart systematically follows a logical check sequence through the instrument and indicates which adjustments must be rechecked after repairing any particular circuit.

A complete test procedure is included which covers adjustment of all circuits for optimum performance. The specifications for the sweep oscillator are given in the front of this manual. The test procedures give additional data for your convenience in analyzing performance. These tests and data are not to be considered as specifications.

Wherever possible, standard components are used in the manufacture of Hewlett-Packard instruments. Your local Hewlett-Packard sales office is a convenient source for special spare or replacement parts; they maintain a parts stock for your convenience. When ordering parts, please specify instrument model and serial number plus the component description and stock number as it appears in the Table of Replaceable Parts (section V).

Your local Hewlett-Packard sales office also maintains complete facilities and specially trained personnel to assist you with any engineering, application, test, or repair problem you may have with the instrument.

4-2. GENERAL PRECAUTIONS.

A. HIGH VOLTAGES. WARNING: Operating potentials as high as 3200 volts are present at certain points in the instrument. The power supplies are all regulated and are capable of delivering relatively high currents for short periods. Unless absolutely necessary do not remove the red safety cover which covers most of the high potential circuits. Remember that the instrument chassis is always grounded by the green grounding wire and NEMA three-prong connector. Do not defeat its purpose with a three-prong to two-prong adapter or by removing the round pin.

B. MAGNET SUPPLY CAUTION. The magnet power supply is isolated from the chassis and the rest of the instrument. This supply operates from a voltage-doubler circuit which is directly connected to the

power line. The cans and/or terminals of all capacitors in the magnet power supply are thus part of the power system. If parts of the circuit which are connected to the ungrounded side of the power line are accidentally shorted to the grounded instrument chassis they may be severely damaged before the fuses can blow. Instrument design holds to a minimum the number of exposed parts which are connected to the ungrounded side of the line (black power cord lead).

Silicon rectifiers are used in the magnet supply. Because of the very low forward resistance characteristic of these units, they will be instantly destroyed if accidentally short-circuited. Be careful when making voltage measurements not to let the probe slip and short-circuit the voltage-doubler circuit.

Voltage measurements other than ripple measurements in this supply should be made with an insulated-case voltmeter. Most electronic voltmeters including the Φ Models 410B and 400D have the ground terminal connected to the instrument chassis and cabinet which is in turn grounded by the green grounding wire in the power cable. Accidentally connecting the meter input ground conductor to the ungrounded power conductor will short out the power source through the "NEMA" ground on the voltmeter chassis. Low level ac ripple measurements must be made with caution. See paragraph 4-7 for procedure.

C. RF OUTPUT CAUTION. Never disassemble the rf cable, balun, or connector. The two tube rf output cable and connector are replaced as a unit. Assembling the cable and connector is difficult, and improper assembly may cause a high swr.

Note: The resistance at the RF OUTPUT connector is zero. This is because a dc short (high impedance to rf) is placed from the rf connector-center conductor to ground. The dc short is placed in the connector to protect operating personnel in the event the capacitor that is connected in series with the two helix breakdown.

D. NEON LAMPS. Neon voltage dividers used as coupling elements in dc coupled circuits are aged, polarized, and selected for correct voltage drop. Refer to paragraph 4-18 for details before replacing any of these lamps.

E. OSCILLOSCOPE. With the application of a positive signal at the horizontal input of the oscilloscope, some oscilloscopes sweep horizontally from left to right, others from right to left. The illustrations in this manual show the oscilloscope horizontal sweeps going from right to left. Thus if an oscilloscope is used with sweeps going from left to right, the mirror image of the oscilloscope sweep on the illustrations present the proper perspective.

F. BWO CATHODE CURRENT. Frequency calibration is slightly affected by bwo cathode current. Therefore to obtain best accuracy: 1) operate with cathode current value at frequency marked on meter plate; 2) make all adjustments with rated cathode current.

4-3. AIR FILTER.

The air filter is located at the rear of the instrument cabinet. Inspect the filter frequently and clean whenever any appreciable amount of dirt has been picked up. Proper attention to maintaining a clean filter will result in long tube and component life.

Clean filter by washing it in a warm water and detergent solution. Before re-installing, recoat the filter with a suitable air filter oil to increase its dirt-holding ability. Air filter oil can be obtained at most heating supply stores or may be obtained through your Hewlett-Packard sales office.

4-4. CABINET REMOVAL.

The cabinet can be removed from the instrument as follows:

- 1) Remove the back.

- 2) Tilt the instrument over on its back. Rest the instrument on a board at least 1-inch thick to avoid crushing the strain feed-through insulator and power cord.

- 3) Loosen the two setscrews on the bottom of the instrument in the front-panel bezel. These screws clamp the front panel in the bezel.

- 4) Lift the cabinet off the instrument.

- 5) To re-install the instrument in the cabinet, perform the above steps in reverse.

4-5. QUICK-CHECK PROCEDURE.

The following test will quickly check the overall performance of the sweep oscillator. All tests are made with the instrument in its cabinet. The tests are given in an order which will provide a minimum of changes in test setups. The setups shown are recommended because they have the required accuracy and use equipment which is generally available. If other components or methods are substituted, it is important to select components which have equal or greater accuracy. Otherwise the error introduced by the measuring equipment may make it appear that the 683C does not meet specifications.

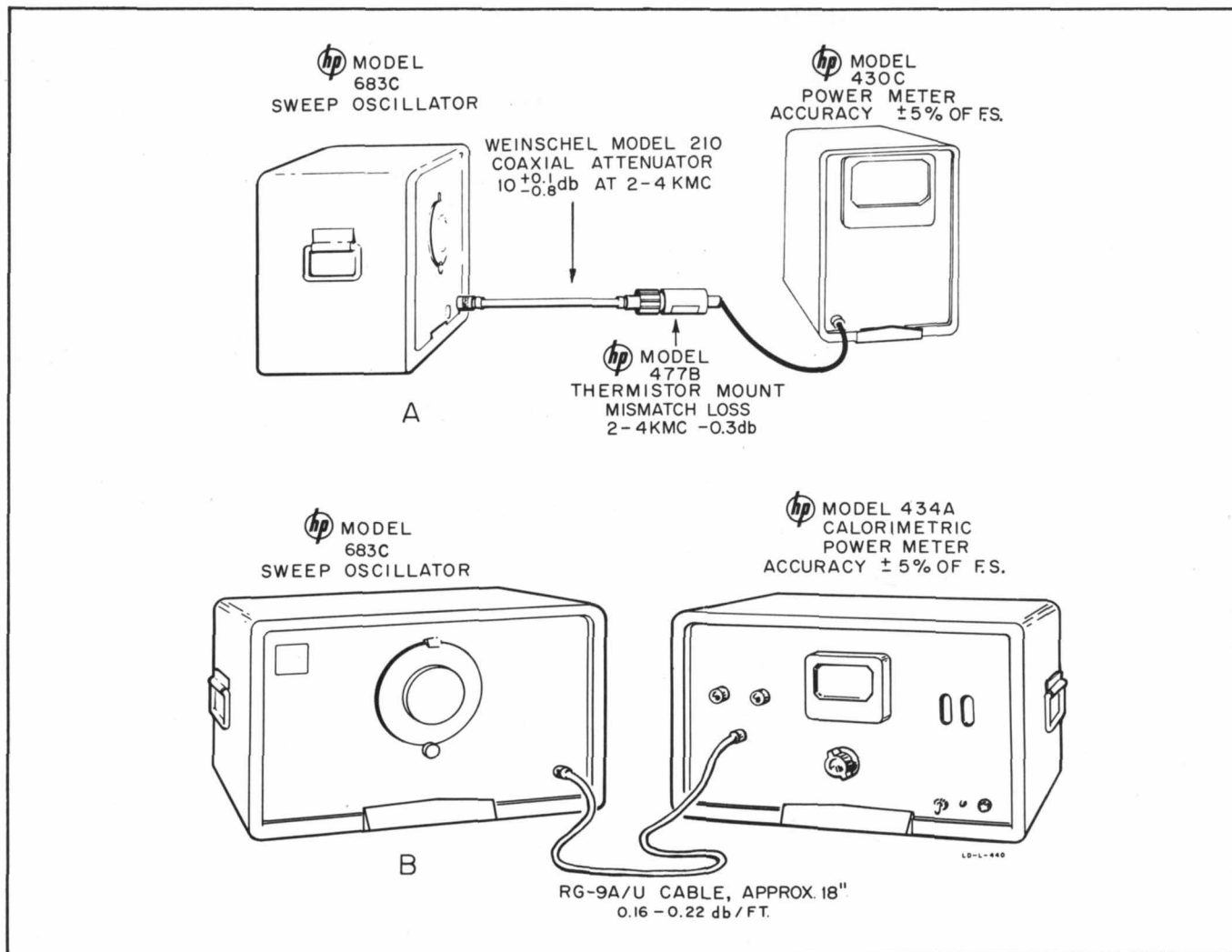

Figure 4-1. Measuring RF Power Output

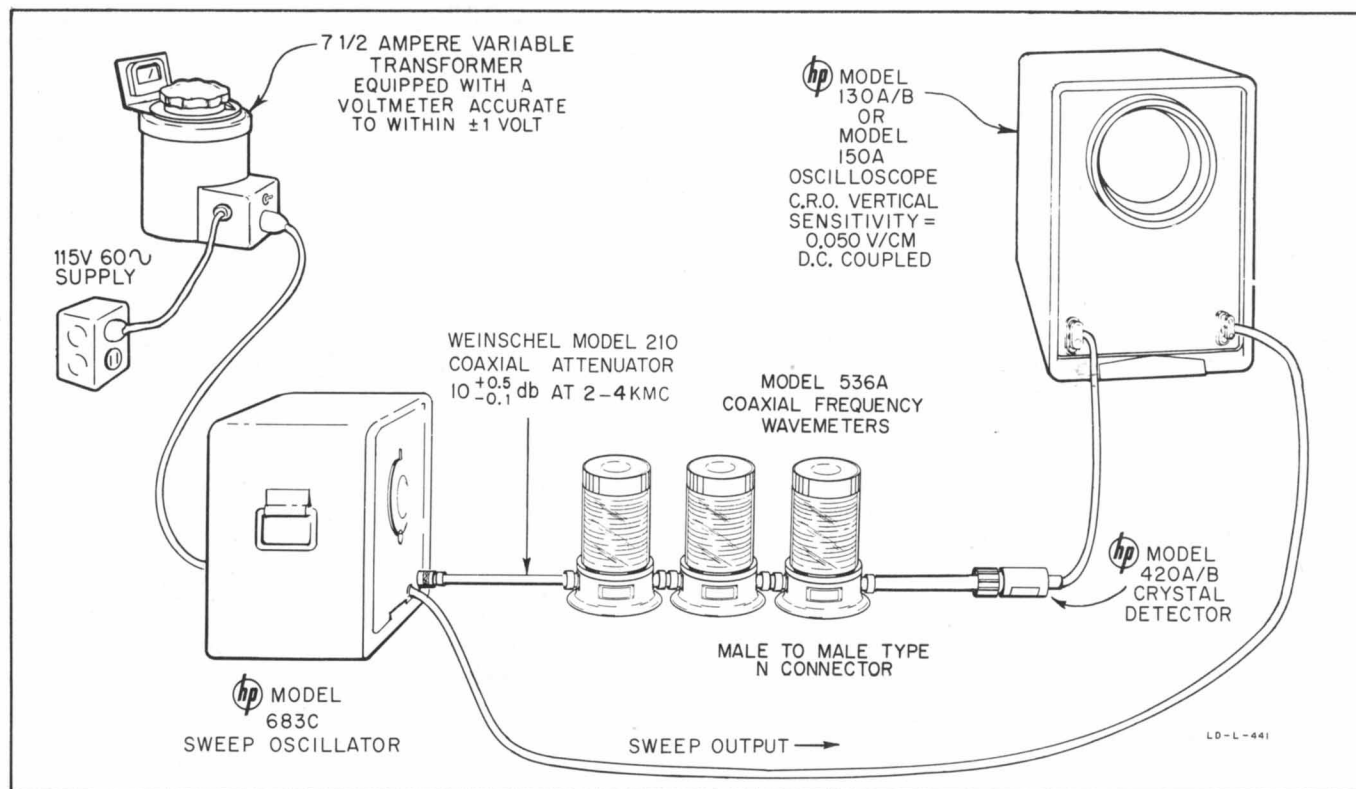

Figure 4-2. Checking Frequency Calibration and General Performance

A. OUTPUT POWER ACROSS THE BAND.

1) Set up equipment as shown in figure 4-1A or B.

Note: The power can be severely reduced by use of excessive lengths of cable or even short lengths which are not in good condition; any discontinuities will cause reflections in the system. When the measurement system includes an attenuator it must have constant attenuation across the band.

2) Turn on equipment and adjust 683C for rated cw output. (Cathode current at value and at frequency setting indicated on meter plate; see figure 2-1.)

3) Allow 15 minutes for the sweep oscillator and the power meter to stabilize.

4) Reduce the 683C power output to minimum with the CATHODE CURRENT control and zero-set the power meter.

When using the hp Model 430C with a 10-db attenuator or directional coupler, zero the 430C on the 10 milliwatt range. If the hp Model 434A Calorimetric Power Meter is used, zero the 434A on the 0.1 watt range.

5) Reset CATHODE CURRENT value at frequency indicated on meter face.

6) Rotate the FREQUENCY dial slowly from one end of the band to the other and note power change.

The minimum output level at any point across the band should be not less than 30 mw (+14.8 dbm). The

difference between the maximum output level and the minimum output level at any two points in the rated range should not exceed 6 db with the leveler off.

Note: Be certain that an apparent excessive power change is not in part due to mismatch in the power measuring equipment. Critical points in the band should be checked with a tunable load in the system. The hp 872A Slide Screw Tuner is suitable for tuning the system over the 2 to 4 kmc (gc) range.

B. FREQUENCY DIAL CALIBRATION.

1) Connect a wavemeter and detector system to the sweep oscillator as shown in figure 4-2.

Note: The use of three wavemeters is a convenience, not a necessity. When one wavemeter is used, change its setting for each frequency check.

2) Adjust the sweep oscillator for rated cw output (see figure 2-1).

3) Tune the wavemeters to 2, 3, and 4 kmc (gc). Rotate SWEEP SELECTOR to RECUR. Δ FREQUENCY to 6.6 and RF SWEEP RATE to 500.

4) Rotate the FREQUENCY dial to the check points and watch for the wavemeter pip. Turn the FREQUENCY dial until the wavemeter pip has moved to the start of the rf sweep. Dial reading should agree within $\pm 1\%$ of the wavemeter reading.

5) Tune the wavemeter to other frequencies and check the dial reading.

C. SWEPT-FREQUENCY OPERATION.

1) Set up the equipment as shown in figure 4-2.

Note: Although this procedure can be performed with one wavemeter, considerable time is saved when three wavemeters are used.

2) Set sweep oscillator to rated cw output and then rotate SWEEP SELECTOR to RECUR.

3) RF Sweep Length:

a. Rotate the Δ FREQUENCY switch to 2.1K and the RF SWEEP RATE switch to 160K. Be sure the Δ FREQUENCY VERNIER is full clockwise, in CAL. position. Set the FREQUENCY dial for 4 kmc (gc).

b. Set the wavemeters to 2, 3, and 4 kmc (gc). The 2 kmc (gc) pip should occur near the end of the sweep trace.

c. Adjust the horizontal gain of the oscilloscope until the 2 and 4 kmc (gc) pips are exactly 8 cm apart.

$$\text{Note: } \frac{2-4 \text{ kmc (gc)}}{8 \text{ cm}} = 250 \text{ mc/cm}$$

Therefore a 2.1 kmc (gc) sweep will be represented by a trace approximately 8.4 cm long.

d. With the low-end wavemeter pip at 8 cm and the high-end pip at 0 cm, sweep length should be between approximately 7.6 cm and 9.2 cm. This represents a rf sweep width of 2.1 kmc (gc) $\pm 10\%$.

4) Sweep Linearity:

With the center-frequency wavemeter set for 3 kmc (gc), the pip should appear at the center of the cro screen at 4 cm ± 0.2 cm (see figure 4-17). The position of the center-frequency pip checks the degree of linearity between the exponential curve needed on the helix of the two tube and exponential sweep generated by the sweep oscillator. If the two exponentials coincide at three points, e.g., top, bottom, and middle, the curves will match at all other points.

5) Δ FREQUENCY Calibration:

Rotate the RF SWEEP RATE switch counterclockwise to each position and observe the position of the wavemeter pips as in 3d and 4, above. With the low-end wavemeter pip at 8 cm and high-end pip at 0 cm, the tolerance ($\pm 10\%$) referred to 8.4 cm (end of the 4.1-kmc [gc] sweep) is ± 0.84 cm. This procedure verifies that Δ FREQUENCY switch calibration is within specifications at its maximum setting.

If it is desired to check the Δ FREQUENCY switch at the other settings, set the RF SWEEP RATE switch at 16K and rotate the Δ FREQUENCY switch through each of its positions, measuring the Δ frequency with

the wavemeters at each step, and computing the error. For sweeps less than full band the specification is +25%, -15% or ± 3 mc, whichever is greater. If the Δ frequency is within specifications for both procedures (with Δ FREQUENCY at 2.1K through all positions of the RF SWEEP RATE switch and with RF SWEEP RATE at 16K through all positions of Δ FREQUENCY) then the Δ FREQUENCY switch is within specifications at all other settings.

D. TRIGGER CHECK.

1) Set up equipment as shown in figure 4-2, except that no wavemeters are required.

2) Rotate RF SWEEP RATE control to 1.6K.

3) Rotate Δ FREQUENCY control to 2.1K, with VERNIER fully clockwise.

4) Rotate SWEEP SELECTOR to TRIG.

5) Push the MANUAL TRIGGER button and observe rf sweep display on the crossscreen. See specifications in subparagraphs C3d and C4.

6) A positive 20-volt pulse (3 v/ μ sec or less rise time) applied to the EXT. TRIG. jack will also initiate a sweep.

E. FREQUENCY STABILITY WITH CHANGING LINE VOLTAGE.

1) Set up equipment as shown in figure 4-2 (only one wavemeter is required).

2) Set the Δ FREQUENCY switch to 6.6 and the RF SWEEP RATE switch to 500.

3) Rotate the SWEEP SELECTOR to RECUR.

4) Set the power line voltage to 103 volts.

5) Adjust sweep width to 10 cm. Thus 1 cm = 0.66 mc.

6) Adjust the rf output to 2 kmc (gc). (This is the most critical frequency.) Tune one of the wavemeters to approximately 2 kmc (gc) so that a pip will appear centered on the cro. Allow frequency to stabilize for about 2 minutes.

7) Increase the line voltage to 127 volts, wait 2 minutes and note the final drift of the wavemeter pip on the screen after the frequency drift has stabilized. Maximum change = 2 mc or about 3 cm on the oscilloscope.

F. MODULATION CHECKS.

1) Set up equipment as shown in figure 4-2, except that no wavemeters are required.

2) Adjust the oscilloscope for internal sweep and sync. Sweep speed should be approximately 0.5 ms/cm.

3) Rotate 683C SWEEP SELECTOR to OFF and AMPL. MOD. SELECTOR to INT.

4) Rotate red knob on AMPL. MOD. SELECTOR, and observe square-wave symmetry as frequency is varied from 400 to 1200 cps. Symmetry is better than 40 to 60%. Verify frequency range by measuring period of one cycle: $2500 \mu\text{sec} = 400 \text{ cps}$ and $833 \mu\text{sec} = 1200 \text{ cps}$.

5) Adjust oscilloscope sweep to free run.

6) Rotate the AMPL. MOD. SELECTOR switch to OFF.

7) With the oscilloscope dc coupled, note the voltage level with the 683C on cw. Adjust the deflection to 5 cm.

8) Switch AMPL. MOD. SELECTOR to INT. and note the amplitude of the square wave. The amplitude should be within 1 db or about 10% of the cw level. With 5 cm deflection on cw this difference will be less than 0.5 cm.

G. RESIDUAL FM. The following simplified test procedure is given for your convenience. A minimum of time and test equipment is required. However this measurement method is valid only when all controls are set as given in the procedure. A method for checking residual fm under cw conditions is given in Hewlett-Packard Application Note 1. This note describes a technique which requires considerable equipment; its use is not necessary to verify normal operation of the instrument. Application Note 1 may be obtained from your local Hewlett-Packard sales office or the Hewlett-Packard Company.

1) Set up equipment as shown in figure 4-2 (only one wavemeter is required).

2) Set output frequency to 2 kmc (gc).

3) Adjust RF SWEEP RATE switch to 500 and FREQUENCY switch to 6.6. Thus with 10 cm deflection on cro, 1 cm = 0.66 mc and 0.2 cm = 132 kc.

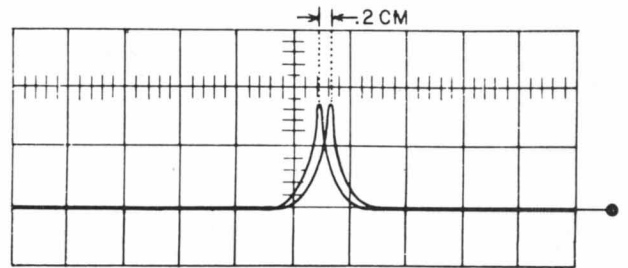

$$\begin{aligned} 2\delta F &= .2 \text{ CM P-P} \\ &= .2 \text{ CM} \times 0.66 \text{ MC} \\ &= 132 \text{ KC} \\ \delta F &= 66 \text{ KC PEAK} \end{aligned}$$

G-5-220

4) Observe jitter in wavemeter pip at 2 kmc (gc). One-half the distance between the pips is the peak residual fm. Residual fm is less than 100 kc peak; 200 kc peak-to-peak $\approx 0.3 \text{ cm}$.

Note: FM will be most pronounced at the low-frequency end of the band and decreases at higher frequencies.

H. RESIDUAL AM.

1) Set up equipment as shown in figure 4-3.

2) Adjust the sweep oscillator for rated cw output.

3) Switch AMPL. MOD. SELECTOR to INT.

4) Adjust CATHODE CURRENT to get a reading of 15 db on the 400D/H/L Voltmeter (db₀).

5) Switch back to cw, and rotate the 400D/H/L switch to the -50 db position. Read db level (db₁).

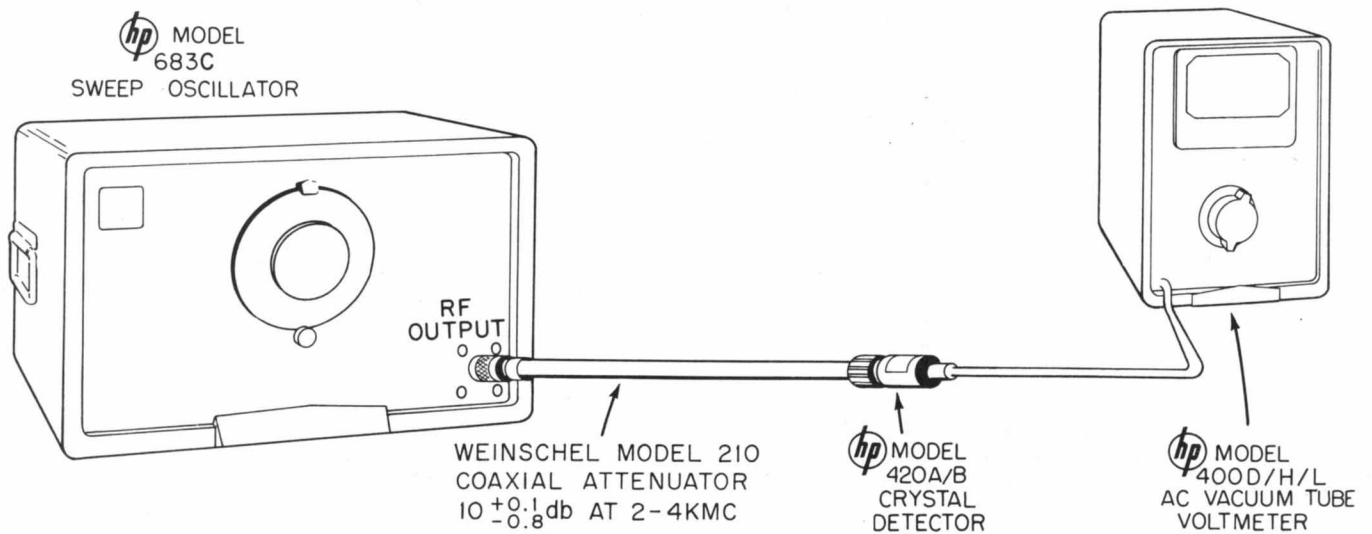

LD - L - 439

Figure 4-3. Setup for Measuring Residual AM

6) The residual am is equal to $(db_0 - db_1) + 8 \text{ db}$.

Note: It can be shown that under the specified conditions of measurement (steps 1 through 5), an 8-db factor is required to obtain the correct value of the residual am. (Specified conditions of measurements are that the output voltage be detected by a crystal detector operating in the square-law region of its characteristic; readings be taken on an average-responding voltmeter.)

This 8-db factor accounts for a) the crystal square-law characteristic and b) the difference between the average values and the peak values of a square wave and a sine wave.

7) Residual am should be 40 db or more below the cw level. Thus the value obtained in step 6 should be greater than 40 db. For example:

$$\begin{array}{r} db_0 \text{ (400D reading, step 4)} \quad -15 \text{ db} \\ db_1 \text{ (400D reading, step 5)} \quad \frac{-(-50 \text{ db})}{+35 \text{ db}} \\ \text{Residual AM} \quad \frac{+8 \text{ db}}{43 \text{ db}} \end{array}$$

4-6. MAINTENANCE TEST EQUIPMENT REQUIRED.

The following test equipment is recommended for the complete adjustment and repair of this instrument.

1) DC vtm, 122 megohms input impedance, accurate within $\pm 3\%$. $\text{\textcircled{hp}}$ 410B dc vtm is recommended. A dc vtm, 200 megohms input impedance, accurate within $\pm 1\%$, such as the $\text{\textcircled{hp}}$ Model 412A.

2) $\text{\textcircled{hp}}$ Model 459A dc resistive voltage divider probe for use with the 410B vtm. The probe divides the input voltage by 100:1 with a rated accuracy of $\pm 5\%$. The probe input impedance is 12,000 megohms. An overall accuracy of 2 or 3% is desirable for these tests. Thus the accuracy of the divider probe should be measured. Rather than trying to calibrate the 410B with the probe, the 410B alone should be accurately calibrated and the percent error introduced by the probe should be measured. Then readings made with the probe can be modified according to the percent error of the probe. This error is constant for all ranges of the meter.

3) AC vtm, 2 megohms input impedance or more, accuracy $\pm 2\%$ of full scale, sensitivity of 0,001 full scale. $\text{\textcircled{hp}}$ Model 400D/H/L or the $\text{\textcircled{hp}}$ Model 403A Transistorized AC VTVM is recommended.

4) Insulated case 5,000 ohms-per-volt or more, rectifier type ac voltmeter (multimeter). The instrument should be calibrated to better than 2% at 6 to 7 volts 60-cycle ac.

5) $\text{\textcircled{hp}}$ Model 150A Oscilloscope with 152B Dual Channel Plug-In Amplifier and Model AC-21A Probe. The probe has an input impedance of 10 megohms shunted by 10 pf and has a voltage division ratio of 10:1.

6) Coaxial attenuator (10 db, 2 to 4 kmc [gc]), such as Weinschel Engineering Company's 210-10.

7) Coaxial wavemeters for the 2 to 4 kmc (gc) range, such as $\text{\textcircled{hp}}$ Model 536A; three wavemeters are desirable.

8) $\text{\textcircled{hp}}$ Model 420A/B Waveguide Crystal Detector.

9) $\text{\textcircled{hp}}$ Model 477B Thermistor Mount.

10) $\text{\textcircled{hp}}$ Model 434A Calorimetric Power Meter, $\text{\textcircled{hp}}$ Model 430C Microwave Power Meter, $\text{\textcircled{hp}}$ Model 431A Power Meter.

11) One variable transformer continuously adjustable from 100 to 130 volts, 7-1/2 amperes capacity. The output voltage must be monitored with a meter accurate to within $\pm 2\%$.

12) $\text{\textcircled{hp}}$ Model 523B or 522B Electronic Counter.

4-7. MAGNET SUPPLY (REGULATED).

A. EQUIPMENT NEEDED.

1) An $\text{\textcircled{hp}}$ Model 403A Transistorized AC VTVM or a 400D ac vtm can be used. If the $\text{\textcircled{hp}}$ Model 400D ac vtm is used, it must be equipped with a three-prong to two-prong adapter or a 1:1 115-volt isolating transformer so that the instrument case can be made floating with respect to ground.

2) 7-1/2 ampere variable transformer equipped with voltmeter of 1% accuracy.

B. MEASUREMENT PROCEDURE.

1) Set line voltage into 683C to 115 volts, and allow instrument to heat 15 minutes. Adjust R30 for a magnet current of 0.7 ampere as read on front panel meter. (Location of R30 is shown in figure 4-5.)

2) Check magnet regulator action by dropping line voltage to 103 volts. Current should not vary more than 0.025 ampere.

3) Repeat with line voltage at 127 volts.

4) Check ripple voltage (note the WARNINGS below). Connect 403A or 400D voltmeter to upper end of R31 (white wire) and right-hand end of R27 (blue wire). See figure 4-4. The wires to the 400D should be twisted to prevent excessive hum pickup. The hum or ripple voltage across the magnet must be less than 100 millivolts with the line voltage varied over any value of the range of 103 to 127 volts.

WARNING

1) When checking ripple voltage, the voltmeter case must be isolated from ground. Temporarily disconnect the voltmeter NEMA ground connector by using a two-prong adapter with the pigtail floating. Place the instrument on an insulated surface. Do not touch the voltmeter cabinet while making this check, as the cabinet is at the same potential as the point under measurement.

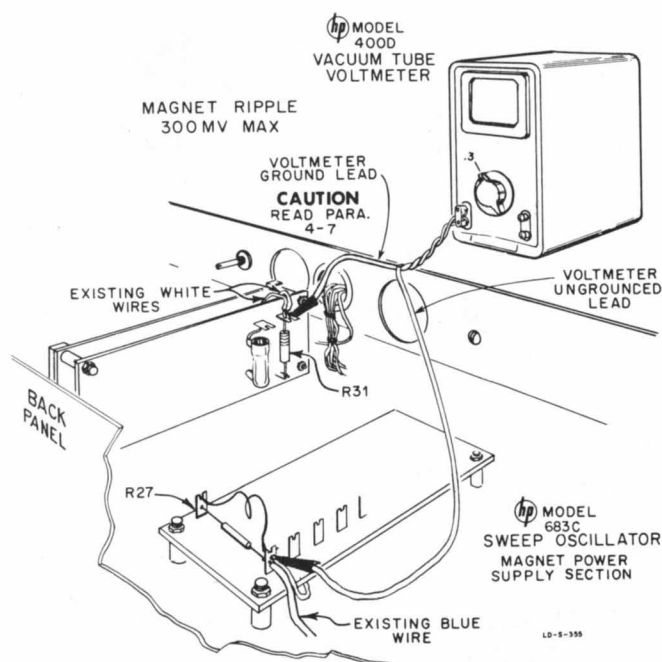

Figure 4-4. Measuring Magnet Circuit Ripple

2) If excessive ripple is measured, check that power cord polarity is correct. Measure the voltage between the white-wire end of R31 and ground. Use a multimeter type ac voltmeter with a dc blocking capacitor in one lead; 6.3 volts ac should be measured.

The magnet power supply uses a voltage-doubler circuit directly connected to the power line. When the power cord is inserted in a polarized three-wire outlet that is properly wired, approximately 150 volts dc and 6.3 volts ac appear between electrical ground and the end of R31 to which the white wires are connected. If the line cord is reversed, approximately 122 volts ac as well as the 150 volts dc will be present on the white lead, which will give a false ripple measurement.

Poor regulation is almost always due to weak tubes. Tubes V1, V2, V3, V4, and V5 should be replaced in that order to locate trouble.

4-8. -150 VOLT REGULATED SUPPLY.

A. EQUIPMENT NEEDED. hp Model 412A dc vtvm to set voltage level and hp Model 403A or 400D/H/L ac vtvm to check ripple.

B. PROCEDURE.

1) Connect the 412A voltmeter from chassis to the -150 volt bus at R129 (150K, white wire; see figure 4-5). Adjust power line voltage to 115 volts.

2) Adjust R148 for exactly -150 volts dc.

3) Drop line voltage to 103 volts and watch for change in -150 volt level. There should be no visible change.

4) Raise line voltage to 127 volts and watch for a change in level; there should be no change in the 412A reading.

5) Connect the hp Model 400D or 403A ac voltmeter from the -150 volt bus to chassis. The ripple voltage must be less than 3 mv over a line voltage range of 103 to 127 volts.

6) Poor regulation and/or ripple are generally caused by weak tubes. Check by replacing one tube at a time with a new, good tube (V107, V108, or V109).

4-9. +300 VOLT REGULATED SUPPLY.

This supply uses the -150 volt bus for a reference voltage. Therefore the -150 volt supply must be working perfectly and be accurately adjusted before the +300 volt supply is adjusted.

A. EQUIPMENT NEEDED. hp Models 412A and 403A or 400D/H/L meters.

B. PROCEDURE.

1) Connect the 412A from chassis to the 300-volt bus at V106, pin 1 (red wire; see figure 4-5).

2) Adjust R141 to obtain exactly +300 volts.

3) Check the regulation by slowly varying the line voltage down to 103 volts and up to 127 volts. There should be no visible change on the 412A voltmeter.

4) Check the ripple voltage with the 403A or 400D voltmeter. The ripple should read less than 10 mv over a line voltage range of 103 to 127 volts.

5) Recheck -150 volt supply and reset, if necessary, then reset +300 volt supply.

4-10. HELIX SUPPLY.

A. EQUIPMENT NEEDED. 410B dc vtvm equipped with 100:1 divider probe as described in paragraph 4-6.

B. PROCEDURE.

1) Check the helix regulator by measuring the voltage from the meter helix shunt to ground. (This measurement point, on CURRENT switch S103, is identified in figure 4-15.) Typically the voltage will vary from +250 volts when the FREQUENCY dial is at the low-frequency end to +2000 volts when the FREQUENCY dial is at the high end.

2) Adjust the FREQUENCY dial until the voltage is 1000 volts. Slowly vary the line voltage from 103 to 127 volts; there should be no visible change on the voltmeter.

3) TURN THE SWEEP OSCILLATOR POWER OFF. Disconnect the two tube high-voltage connector (figure 4-5). Series three 100K, 1-watt resistors, and connect them from the two tube side of overload relay K103 (figure 4-16) to ground. Rotate the FREQUENCY dial to the low end. Rotate the CATHODE CURRENT control full counterclockwise.

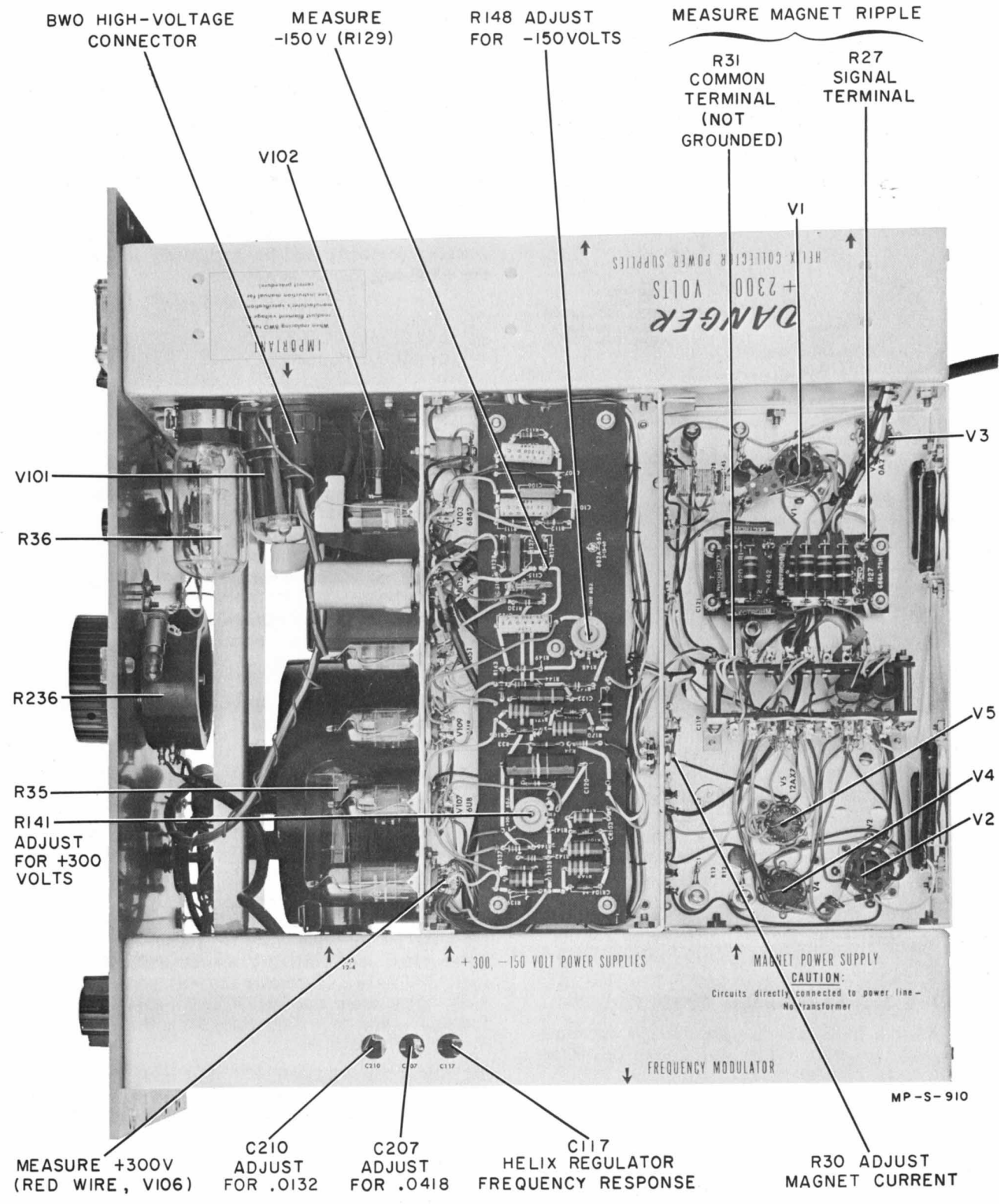

Figure 4-5. Model 683C Top View

- 4) Connect a voltmeter across the series resistors. Turn on the equipment. There will be approximately 250 volts across the resistors.
- 5) Slowly rotate the FREQUENCY dial toward the high-frequency end and watch the rising voltage across the resistors. When the voltage reaches 1000 to 1100 volts the overload relay should operate and cut off the high-voltage circuits. This corresponds to the 3.5 ma (approximately) required to operate helix overload relay K103.
- 6) Pad K103 if it operates at too low a current. A 50,000-ohm resistor will increase the current required to operate K103 by about 10%.

4-11. FILAMENT REGULATION.

The two, helix control circuits, and the sweep generator circuit are all operated from regulated filament supplies. The regulated filament supply circuits must be adjusted accurately, otherwise associated tubes and circuits will be affected drastically.

The voltage on the two tube filament is critical and will affect the life of the tube. The filament voltage is nominally 6.3 volts. When a new tube is installed make sure that the voltage is adjusted to agree with the tube manufacturer's specifications furnished with the replacement tube.

The best way to adjust the two tube filament voltage is to adjust the line voltage to 127 volts and then adjust the value of shunt pad resistors R37, R38, and R39 (figure 4-16) until the voltage is near the high safe limit, as specified by the manufacturer. The ballast tube (R36) will then hold filament voltage within 0.1 or 0.2 volt at lower line voltage. Note: If ballast tube must be replaced, it must be aged for 24 hours. Aging minimizes filament voltage fluctuation once filament voltage limits have been set.

WARNING

BE CAREFUL WHEN MAKING CONNECTIONS. Very high voltage exists in this area. Be certain the equipment is off before connections are made or broken or padding resistors are changed. Use insulated clips to avoid accidental short circuits.

When adjusting two tube filament voltage, first connect an accurate insulated-case ac voltmeter across the two filament shunt resistors. These resistors are located under the red safety cover and are identified in figure 4-16. The padding should be adjusted so that the filament voltage does not exceed the optimum value by more than 0.2 volt with the line voltage adjusted to 127 volts. The regulator should not allow the voltage to go more than 0.2 volt below the optimum value at 103 volts. When checking the voltage at the limits, allow the line voltage to remain at 103 or 127 volts for several minutes so that the ballast tube completely stabilizes. The padding resistors should have sufficient wattage rating. Use 2-watt carbon resistors down to 36 ohms and 5-watt wire-wound resistors if under 36 ohms, or use parallel combinations of 2-watt carbon resistors greater than 36 ohms to get low values.

Quite often, malfunctioning of the sweep generator circuit can be traced to low or high filament voltage. A filament voltage change affects tube contact potential due to the change in emission current. A change in contact potential will shift the gating point of schmitt trigger V201 and clamp point of clamp diode V204B.

To set the helix control circuit and sweep circuit filament regulator, follow the same procedure as for the two filament regulator. Using an insulated-case voltmeter, measure the voltage across shunt resistor R32 (39 ohms). (R32 is located on a long horizontal resistor board -- see figure 4-15.) Voltage measured must not exceed 6.4 volts at 127-volt line or 6.1 volts at 103-volt line. Pad R32 as necessary to get proper range.

4-12. MEASUREMENT OF LINEAR SWEEP TIMES.

A. EQUIPMENT NEEDED. Counter with facilities for time interval measurements: Φ Model 523B or 522B Electronic Counter is recommended; Φ Model 412A dc vtvm, Φ Model 150A or 130A/B oscilloscope.

B. PROCEDURE. Note: Controls specified in the following instructions assume the use of an Φ electronic counter.

- 1) Measure the -150 volt and +300 volt supply voltages and set as described in paragraphs 4-8 and 4-9. Be certain to set the -150 volt supply first.
- 2) Measure sweep amplitude (at SWEEP OUTPUT jack). Sawtooth should be between 20 and 25 volts (see figure 4-6). If sawtooth is not within these limits, first check the regulated filament voltage (see paragraph 4-11), and then check V202 and the other tubes in the linear sweep time circuit. If filament voltage is correct and all tubes are good, pad R212 to obtain a sawtooth of between 20 and 25 volts.
- 3) Connect the junction of R207 and R208 to the counter trigger input (START connector).
- 4) Set counter input switch to COMMON.
- 5) Set counter TRIGGER SLOPE START switch to (-) and STOP switch to (+).

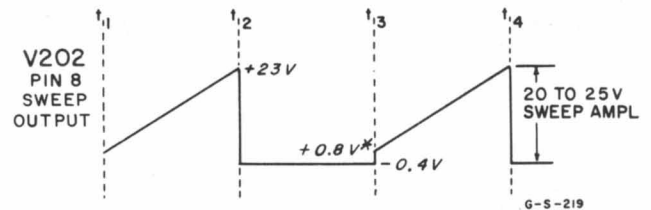

* VALUE VARIES WITH SETTING OF RF-SWEEP START VOLTAGE. [PARA. 4-14(7)]

Figure 4-6. Sweep Output Voltage

- 6) Rotate 683C SWEEP SELECTOR switch to RECUR.
- 7) Rotate Δ FREQUENCY switch to 2.1K, RF SWEEP RATE switch to 160K.
- 8) Set up counter TIME UNIT switch so that the decimal point will give a 13.2-millisecond reading.
- 9) Set counter START TRIGGER level and STOP TRIGGER level to about -3 volts.
- 10) The counter should read between 12.7 and 13.7 ms with 683C line voltage at 115 volts. If out of specifications, adjust C207 (figure 4-5) for 13.2 ms sweep time.
- 11) Rotate RF SWEEP RATE switch to 50K and read sweep time. The counter should read 40.0 to 43.6 ms with 683C line voltage at 115 volts. If out of specifications, adjust C210 (figure 4-5) for 41.8 ms.
- 12) Rotate RF SWEEP RATE to 16K. Read sweep time on counter. The limits are 127 to 137 ms. Check the sweep time with RF SWEEP RATE at 5K. The limits are 400 to 436 ms. If either sweep time is out of specifications, correct the setting of R225 (figure 4-15) so that for both the 16K and 5K positions of RF SWEEP RATE the sweep times are within the specified limits.
- 13) Repeat step 12 for sweep rates of 1.6K and 500. Specifications: 1.27 to 1.37 sec and 4.0 to 4.36 sec. If out of specifications, adjust R226 (figure 4-15).
- 14) Repeat step 12 for sweep rates of 160 and 50. Specifications: 12.7 to 13.7 sec and 40.0 to 43.6 sec. If out of specifications, adjust R227 (figure 4-15).
- 15) Measure sweep time with RF SWEEP RATE at 16. Specifications: 127 to 137 sec. Generally no adjustment should be required. However, if specifications are not met, change the value of R232 slightly. (R232 is a 3.3 megohm resistor on switch S203; see figure 4-15.)
- 16) Connect the SWEEP OUTPUT to the vertical input of the oscilloscope. Set the RF SWEEP RATE switch to 160K and Δ FREQUENCY switch to 2.1K. Adjust the oscilloscope controls to display a 20- to 25-volt sawtooth voltage of 13- to 14-ms duration.
- 17) Measure the sweep starting voltage which will appear as a vertical step at the beginning of the sawtooth (see figure 4-6). The step must be between 1 and 2 volts. If necessary, adjust R217 (figure 4-15) to obtain approximately 1.5 volts. Final adjustment is made when making the rf sweep adjustments (paragraph 4-14, step 7).

4-13. REPLACEMENT OF BWO TUBE, AND CALIBRATION PROCEDURE.

Always handle the bwo tube with extreme care. The tube is very expensive and can be damaged by improper handling. The tube never should be removed from the capsule for any reason! Read all the removal and installation instructions before proceeding.

Handle the old tube as carefully as a new tube when the old tube is to be returned for warranty adjustment. Follow shipping instructions carefully since no allowance will be made on a tube which is broken when it reaches the manufacturer. In addition give complete information regarding the cause of bwo tube failure, if possible.

A. REMOVING THE BWO TUBE.

- 1) Disconnect power from the instrument and remove the cabinet.
- 2) Disconnect the bwo tube multi-conductor high-voltage cable connector (figure 4-5) from its mating receptacle located at the left-hand side of the instrument, as seen from the front. Disconnect lead to bwo control grid.
- 3) Remove the four screws which hold the balun transformer (identified in figure 4-15) and type N connector to the front panel. Be careful to save the screws. Do not remove the coaxial cable from the balun transformer. Do not disassemble the balun transformer.
- 4) With a #10 allen wrench mounted in a driver handle 8 to 10 inches long, back off the two #10 allen screws at the front and rear of the magnet castings. Note: #10 allen drivers can be ordered from the Hewlett-Packard Company. The stock number is given in section V, Table of Replaceable Parts, under miscellaneous. (These screws bear against the tube capsule.) The front screws are easily seen and are accessible from the top and right side of the instrument. Back them off about 1/2 inch. The two rear screws are not seen so easily since they are under the top and side deck. One screw is accessible from a hole near the magnet supply resistor board on the top of the instrument, and the other through a hole above XV208 on the side of the instrument. The angle at which the wrenches make contact with the screws is indicated in figure 4-9. Looking into the magnet from the rear of the magnet, the screws may be seen. Back them off until they are out of contact with the capsule; this will be approximately 1/2 inch.
- 5) Carefully remove the capsule from the rear. Feed the high-voltage cable and connector through the magnet core.
- 6) Follow the Backward-Wave Oscillator Tube Claims and Adjustment Procedure instructions in this manual. Pack the bwo tube, output cable and balun transformer with connector, as directed, to insure safe arrival at the factory.

B. INSTALLATION OF A NEW BWO TUBE.

- 1) Carefully feed the multi-conductor high-voltage connector through the rear of the magnet towards the front panel. The #10 allen screws at the ends of the magnet should be backed out 1/2 inch so as to not catch on the connector.

2) The two tube should be installed so that the rear of the capsule is approximately 3-3/8 inches (see figure 4-7) from the bracket which supports the magnet. The output fitting should be pointing downward to the left at an angle of about 45° (see figure 4-9).

3) Adjust the two rear #10 allen screws so the capsule is accurately centered in the magnet hole.

Note: The capsule is supported at three points which are 120° apart. One is a spring-loaded ball and the other points are the two #10 allen screws. By carefully adjusting the two screws the capsule can be firmly supported and accurately centered (see figures 4-8 and 4-9).

4) Install and connect to the front panel the balun transformer with type N connector.

5) Repeat the centering process with the front two screws (see figure 4-9). It is not possible to exactly center the capsule by eye with the front screws. However, it is necessary to be as close as possible before a final electrical adjustment is attempted.

6) Mount the new current plate (furnished with the replacement tube) on the meter.

7) Reconnect the high-voltage connector and two grid lead.

8) By eye, recheck the mechanical positioning of the two tube in the rear. If necessary, readjust the #10 allen setscrews to accurately center the capsule in the hole.

9) Set front panel controls as follows:

CATHODE CURRENT . . . extreme counterclockwise
 AMPL. MOD. SELECTOR OFF
 SWEEP SELECTOR OFF
 Δ FREQUENCY 66
 RF SWEEP RATE 1.6K
 CURRENT selector CATH.
 FREQUENCY dial 2 KMC
 RF LEVELER OFF

10) Refer to filament regulator adjustment instructions (para. 4-11). Connect an accurate ac voltmeter with an insulated case to the two tube filament circuit.

11) Turn on power to the sweep oscillator and adjust the line voltage to 127 volts. Carefully watch the two filament voltage for 2 minutes. If the voltage exceeds the rated voltage by more than 0.2 volt, immediately turn the instrument off and readjust the value of the padding resistors (R37, R38, and R39, figure 4-16).

12) After accurately setting the filament voltage at 127 volts line, reduce the line voltage to 115 volts and turn off the instrument.

13) Insert two insulated #10 allen drivers with approximately 8-inch long handles into the two front positioning screws.

WARNING

Wrap the shafts with insulating tape to avoid shorting out adjacent circuitry.

14) Turn on instrument. After two minutes, adjust CATHODE CURRENT control to obtain 1 ma cathode current.

15) Rotate CURRENT selector switch to HELIX and read the helix current. Adjust the position of the two capsule by simultaneously turning the two #10 allen screws. Position the tube for minimum helix current.

16) Rotate CURRENT selector to CATH. Operate CATHODE CURRENT control to increase cathode current to value marked on panel meter. Return CURRENT selector to HELIX, again read the helix current, and position the tube for minimum current. With the final positioning, the helix current must be less than 3 ma unless cathode current exceeds 7 ma.

17) Return CURRENT selector to CATH. Adjust R332 (figure 4-16) to give 1 ma more than rated cathode current with CATHODE CURRENT control set full clockwise (see paragraph 4-16 for adjustment procedure). Return CATHODE CURRENT control to setting which gives rated current.

18) Check frequency calibration.

C. FREQUENCY CALIBRATION.

1) Set up test equipment as in figure 4-2.

Note: If desired, one wavemeter may be used instead of three.

2) Turn FREQUENCY dial to 2 KMC cw output, and adjust wavemeter to 2 kmc (gc). If necessary, adjust R132 (figure 4-15) to make dial setting agree with wavemeter.

3) Turn FREQUENCY dial to 4 kmc (gc) and set wavemeter to 4 kmc (gc). Adjust R135 (figure 4-15) to bring output frequency into agreement with wavemeter.

4) Repeat these two checks at 2 and 4 kmc (gc), and refine the adjustments.

5) Adjust, by padding or selection, the value of R234 (figure 4-15), if necessary, to make 3.1 kmc (gc) track.

6) Adjust sweep oscillator to sweep the full band, and set up the three wavemeters at 2, 3, and 4 kmc (gc). Check linearity as described in proof of performance tests, Swept-Frequency Operation, paragraph 4-5C. If linearity is not within specifications, refer to paragraph 4-14, RF Sweep Linearity.

D. OUTPUT POWER CHECK.

1) Check power output across the band as described in paragraph 4-5A. Inability to get full power at some frequencies or excessive power change vs frequency when operating into a matched load is due to a defective two tube.

Note: Be certain that an apparent excessive power change is not in part due to mismatch in the power measuring equipment. Critical points in the band should be checked with a tunable load in the system. The Model 872A Slide Screw Tuner is suitable for tuning the system over the 2 to 4 kmc (gc) range.

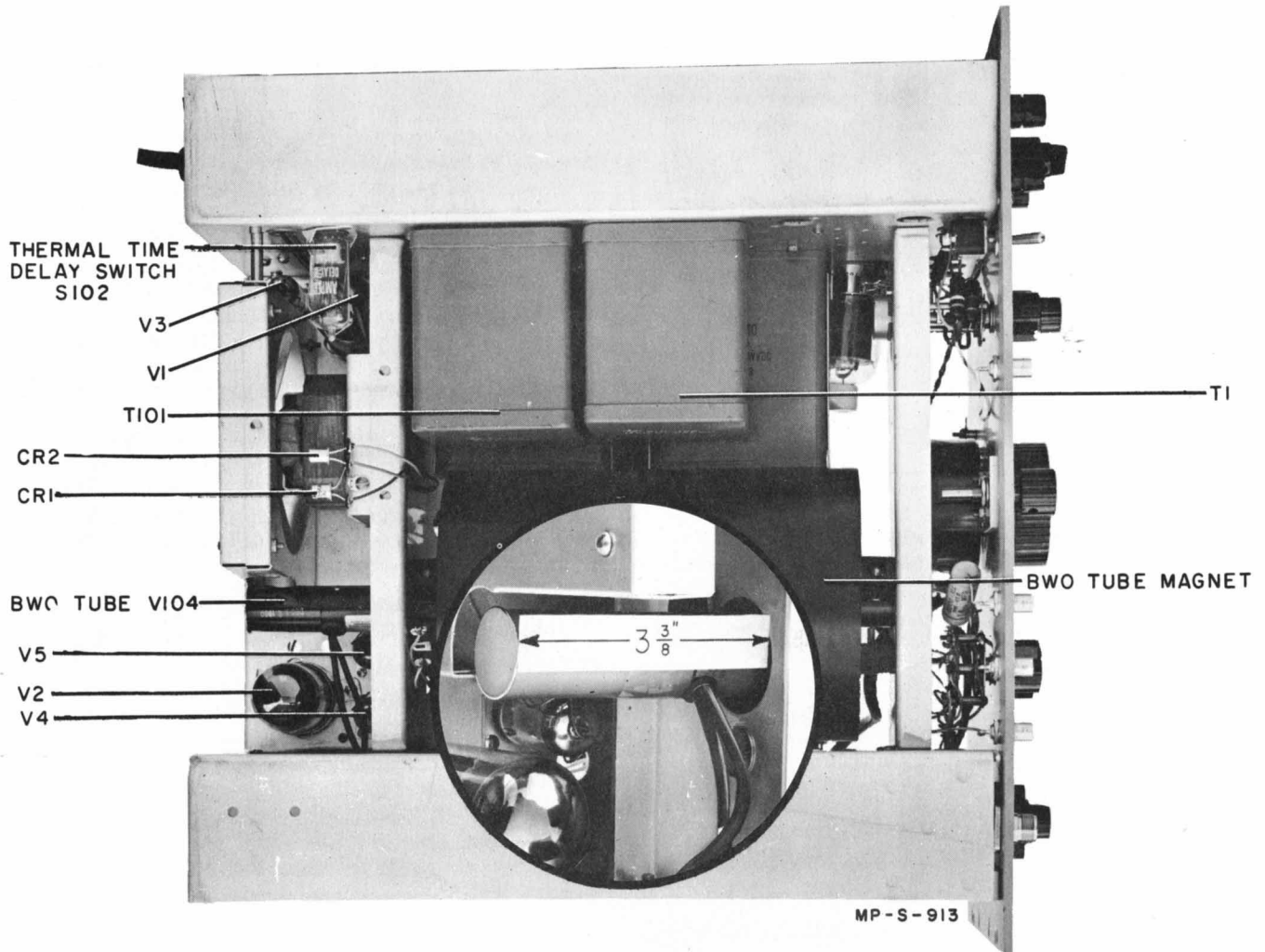

Figure 4-7. Model 683C Bottom View

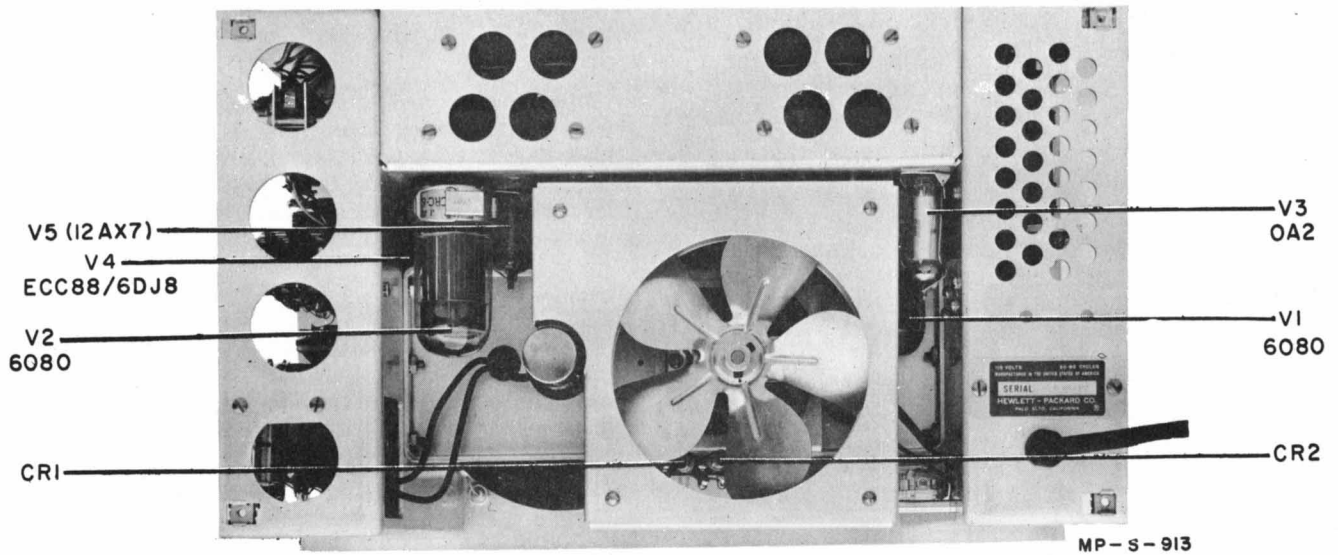

Figure 4-8. Model 683C Rear View

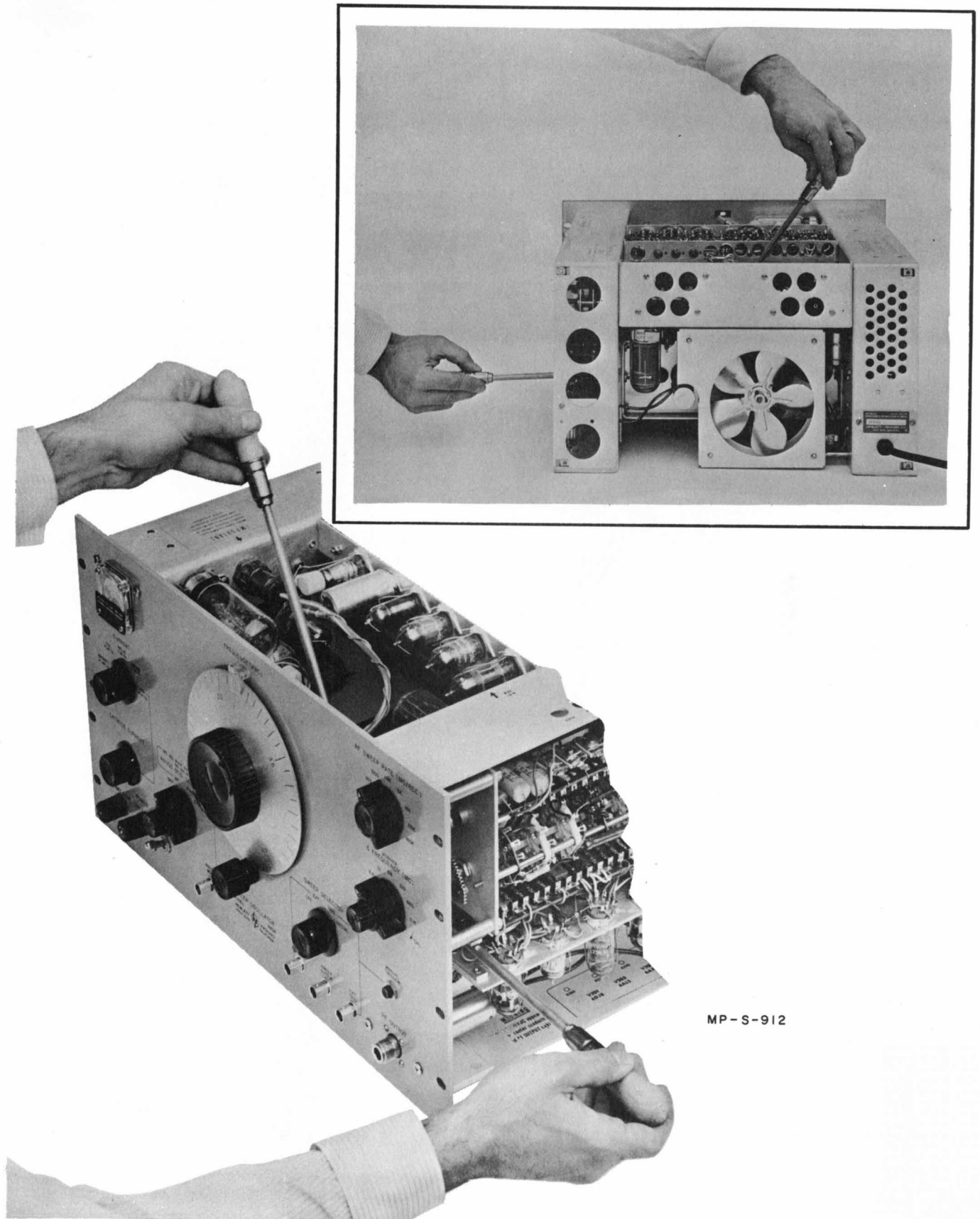

Figure 4-9. Positioning the BWO Tube at the Front and Rear of Magnet

4-14. RF SWEEP LINEARITY.

Allow instrument to operate at least 1/2 hour before making adjustments.

Note: Though it is not recommended, this procedure can be performed with one wavemeter. The use of three wavemeters saves considerable time.

- 1) Set up test equipment as in figure 4-2.
- 2) Set the wavemeters to 2, 3, and 4 kmc (gc).
- 3) Turn RF SWEEP RATE to 50K.
- 4) Set the Δ FREQUENCY switch at 2.1K, and FREQUENCY dial for 4.1 kmc (gc).
- 5) Adjust vernier on horizontal input sensitivity control of oscilloscope so that sweep trace is approximately 8.5 cm.
- 6) With R244 (figure 4-15), adjust sweep linearity in a direction which centers the 3 kmc (gc) pip between the 2- and 4-kmc (gc) pips (see figure 4-10). If the 2 kmc (gc) pip moves off the scope face it can be brought back by adjusting rf sweep length with R246, located near R244.

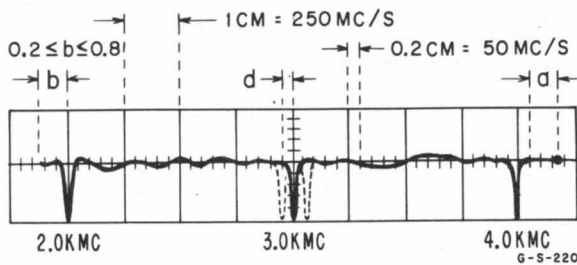

Figure 4-10. Calibration Pips on CRO Sweep

- 7) Adjust oscilloscope horizontal gain so that 2- to 4-kmc (gc) trace = 8 cm.

- a = 0.5 cm (adjust with R217, figure 4-15).
- b = within 0.2 cm to 0.8 cm (if not, adjust R246 to bring the 2-kmc (gc) wavemeter pip 0.5 cm from the end of the sweep).
- c = ± 0.2 cm (adjust R244: since R244 and R246 interact, check that b remains within specifications).

- 8) Turn RF SWEEP RATE to 160K.
- 9) Adjust R245 to bring b to 0.5 cm (specification: 0.2 to 0.8 cm when total sweep length is approximately 8.5 cm).
- 10) Adjust vernier of cro horizontal amplifier so that 2- to 4-kmc (gc) trace is exactly 8 cm in length.
- 11) Check that d (linearity) is within ± 0.2 cm. If linearity d is not within specifications, correct the

error with R244. Do not change the setting of R244 without checking all previously-adjusted positions (by returning RF SWEEP RATE to 50K and repeating steps 6 through 11).

- 12) Repeat steps 8 through 11 with RF SWEEP RATE at:

- 32K (adjust b with R247)
- 10K (adjust b with R248)
- 3.2K (adjust b with R249)
- 1K (adjust b with R250)
- 320 (adjust b with R251)

Do not change the setting of R244 without checking all previously-adjusted positions.

Note: When RF SWEEP RATE is set for the faster sweep rates (160K to 1.6K), it is practical to adjust the oscilloscope for a 2- to 4-kmc (gc) trace of approximately 8 cm and to read linearity (d) directly. For the slower sweep rates (RF SWEEP RATE on the 500 to 16 positions) probably it will be more practical to calculate linearity (d) and sweep length (b).

Calculation procedure: Record (in cm) the positions of the 2, 3, and 4 kmc (gc) pips, and the end of the sweep. Determine linearity and sweep length, and calculate the error.

Example: Linearity and sweep length error are calculated for the sweep shown in figure 4-11A.

Since the rf sweep starts at the high-frequency end, numbering on the graticule horizontal axis is from right to left. For convenience, the 4-kmc (gc) pip (rather than the start of the sweep at 4.1 kmc [gc]) is designated 0 cm.

- 4 kmc (gc) pip = 0 cm
- 3 kmc (gc) pip = 4.4 cm
- 2 kmc (gc) pip = 8.4 cm
- End of sweep = 9 cm
- Start of sweep = +0.2 cm

Determining linearity (d) error:

$$\% \text{ error} = \frac{P_{cf} - 0.5L}{0.5L} \times 100$$

where P_{cf} = position of center-frequency pip (distance in cm from high-end pip)
L = band length in cm (distance between end pips)

0.5L = band midpoint in cm

For the sweep shown in figure 4-11A:

$$P_{cf} = 4.4 \text{ cm}$$

$$0.5L = 4.2 \text{ cm}$$

$$\% \text{ error} = \frac{4.4 \text{ cm} - 4.2 \text{ cm}}{4.2 \text{ cm}} \times 100 = +4.8\%$$

Linearity specification: Position of center-frequency pip in cm shall be within $\pm 5\%$ of band midpoint in cm.

Thus the sweep shown in figure 4-11A meets the linearity specification.

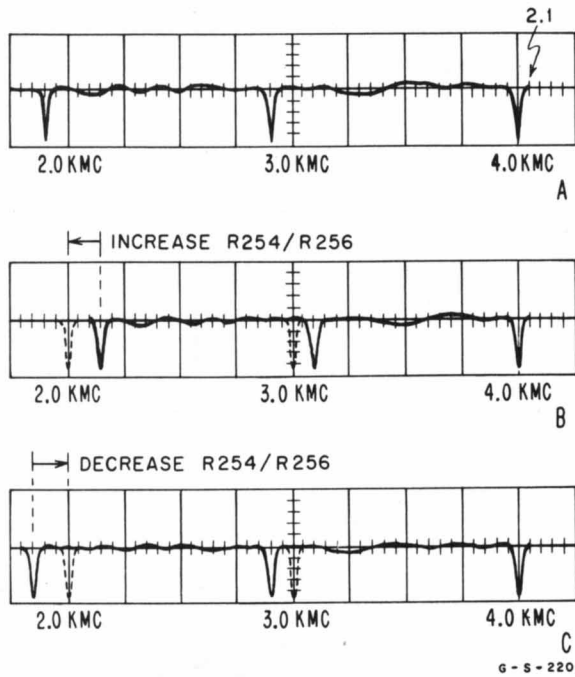

Figure 4-11. Example of Calibration Pips on CRO Sweep

Determining sweep length (b) error:

$$\% \text{ error} = \frac{L_a - L_d}{L_d} \times 100$$

where L_a = actual sweep length in cm
 L_d = desired sweep length in cm

For the sweep shown in figure 4-11A:

$L_a = 9.2 \text{ cm}$
 $L_d = 8.8 \text{ cm}$

To obtain L_d , use the expression $\frac{\Delta F}{B} \times L$

where ΔF = sweep band in kmc (gc) (2.1 kmc [gc])
 B = frequency in kmc (gc) between end pips (2 kmc [gc])
 L = distance in cm between end pips (8.4 cm)

$$\% \text{ error} = \frac{9.2 - 8.8}{8.8} \times 100 = +4.5\%$$

Sweep length specification: $\pm 10\%$ with Δ FREQUENCY set at 2.1K.

Thus the sweep shown in figure 4-11A meets the sweep length specification.

13) Turn RF SWEEP RATE to 50.

14) Repeat steps 8 through 11, selecting a value for R254 (figure 4-15) to bring b within specifications. Figures 4-11B and 4-11C show the direction of resistance correction for 1) a short sweep and 2) a long sweep.

15) Turn RF SWEEP RATE to 16, selecting a value for R256 (figure 4-15) to bring b within specifications. See figures 4-11B and 4-11C.

4-15. SQUARE-WAVE GENERATOR.

A. ADJUSTING SQUARE-WAVE SYMMETRY. Equipment required: High-frequency oscilloscope, such as Φ 150A; oscilloscope probe, such as the AC-21A.

Procedure:

1) Set SWEEP SELECTOR at OFF, AMPL. MOD. SELECTOR at INT., and INT. SQ. WAVE FREQUENCY (vernier on AMPL. MOD. SELECTOR full counterclockwise).

2) Connect probe at pin 3, V301.

3) Adjust R310 (identified on figure 4-13) for square-wave symmetry of 40 to 60%, or better over the 400 to 1200 cps range.

B. DIODE CR301. Diode CR301 is a silicon diode. Leakage current is less than 10 microamps at -10 volts. Measurements should be made at approximately 25°C.

4-16. RF LEVELER AND REFERENCE ANODE VOLTAGE ADJUSTMENT.

The programming and reference anode voltages are supplied by the rf leveler circuit. When either re-focusing the bwo in the instrument or installing a new bwo tube, the rf leveler must be recalibrated and reference power level re-established.

A. SPECIAL TEST EQUIPMENT. An oscilloscope with a dual channel amplifier is needed for this procedure. The Φ Model 150A oscilloscope with a 152B dual channel amplifier is recommended.

B. POWER LEVELER CIRCUIT CALIBRATION.

1) Obtaining reference power level:

a. Set up 683C as shown in figure 4-14.

b. 683C front panel control settings:

SWEEP SELECTOR OFF
 RF SWEEP RATE 160K MC/SEC
 Δ FREQ. 2.1K MC
 VERNIER CAL
 RF LEVELER OFF
 AMPL. MOD. SELECTOR OFF
 CURRENT selector CATHODE
 CATHODE CURRENT max cw

c. With Balance Adj. R335 mid-range, adjust DC Level Adj. R332 (figure 4-13) to cathode current and at frequency indicated on meter face.

d. Turn SWEEP SELECTOR to RECUR.

- e. Check FREQUENCY dial calibration at 2, 3 and 4 kmc (gc). If recalibration is necessary, see paragraph 4-13C Frequency Calibration.
- f. Rotate SWEEP SELECTOR to OFF, FREQUENCY dial to 2 KMC.
- g. Control settings for the Φ Model 431A Power Meter:
POWER RANGE as needed
INPUT Z 200 for Φ 478A
BIAS CURRENT . . Setting needed for zero-set
- h. Rotate the AMPL. MOD. SELECTOR to PULSE and zero-set the power meter.
- i. Rotate CATHODE CURRENT control R327 full clockwise.
- j. Rotate FREQUENCY dial across the band and check that:

(1) Minimum power across the band should be greater than 30 milliwatts (14.8 dbm). If minimum power is less than 30 milliwatts increase cathode current with dc level adj. R332.

(2) Power spread from high to low power point across the band should be less than ± 3 db. If power spread is too great, decrease cathode current slightly.

- k. Readjust dc level potentiometer R332 clockwise until minimum power point is greater than the specified 30 milliwatts (14.8 dbm). Record cathode current value at frequency at which minimum power point exists.

2) Determining crystal detector-attenuator power response:

- a. Rotate FREQUENCY dial to 2 kmc (gc).
- b. Rotate CATHODE CURRENT control clockwise until 30 milliwatts (14.8 dbm) is obtained on the power meter.
- c. Rotate 683C SWEEP SELECTOR to RECUR. DO NOT MOVE THE CATHODE CURRENT control.
- d. Set the oscilloscope for dc coupling.
- e. Rotate the AMPL. MOD. SELECTOR switch to PULSE.
- f. For an rf reference draw a line with a grease pencil at some arbitrary point on the oscilloscope graticule. Set the oscilloscope beam at the rf reference line (see figure 4-12).
- g. Rotate the AMPL. MOD. SELECTOR to OFF.
- h. The point at which the oscilloscope electron beam deflects vertically from the reference line is the 30 milliwatt point at 2 kmc (gc). Place a mark on the oscilloscope graticule as shown in figure 4-12.

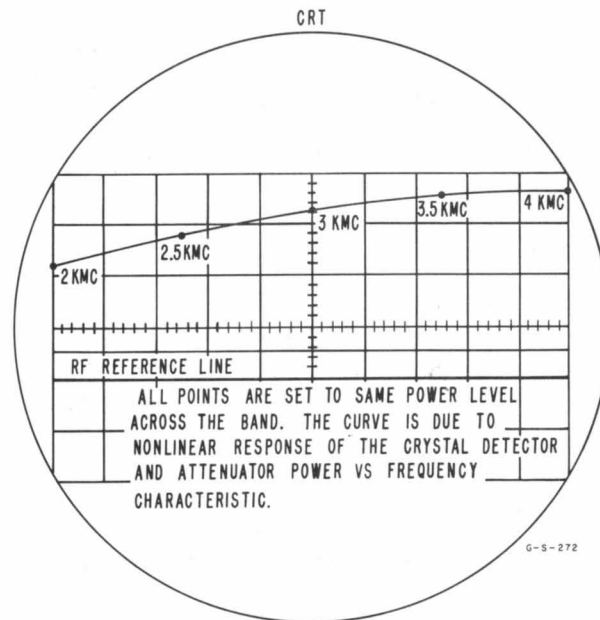

Figure 4-12. Crystal Detector-Attenuator Response Curve

- i. Repeat steps a through h at 2.5, 3.0, 3.5, 4.0 kmc (gc).

Note: As each point is plotted on the oscilloscope, the oscilloscope HORIZ. POS. control must be rotated to move the power point to a new position on the graticule (see figure 4-12). The space between positioned plots on the oscilloscope graticule can be easily interpolated. With oscillator power output a constant across the band, any indicated power variation is due to the characteristic of the crystal detector and attenuator used in the test setup. If not compensated for, these will introduce appreciable error.

- j. Connect points on the graph (see figure 4-12). This will give a permanent record of the power-line curve for the particular crystal and attenuator used.

3) Segment adjustment procedure:

- a. With 683C setup as shown in figure 4-14, connect a test probe (not shown) from the anode meter shunt of the bwo (see figure 4-16) to oscilloscope channel B.
- b. 683C settings same as 1b except:

(1) CATHODE CURRENT set to value and at frequency recorded in step 1k.

(2) SWEEP SELECTOR to RECUR.

Note: The RF SWEEP RATE, 160K position, should be roughly calibrated. See paragraph 4-14 RF Sweep Linearity steps 1, 2 and 8 through 10.

- c. Remove wavemeters from setup.

CAUTION

Be careful that there are no holes across the band due to either poor rf connections or impedance mismatches.

- d. RF LEVELER switch to ON.
- e. Level the coarse grain power variations (figure 3-3) of the rf power output presentation on the oscilloscope to the rf power-line curve.
 - (1) Adjust segment 1, R321 (figure 4-13) as shown in step 1.
 - (2) Adjust segment 2, R324 (figure 4-13) as shown in step 2.
 - (3) Adjust segment 3, R315, and segment 4, R320 (figure 4-13) as shown in step 3. After making all four adjustments readjust segments 1, 2, 3 and 4 as needed to obtain optimum leveling action.

Note: There will be interaction between segment 2 and segment 3 since the height to which segment 3 rises is a function of the parallel resistance of plate-load resistor R318 of V302A and R232, plus a section of R324. This interaction makes available a wide range of leveler shapes. There will also be a slight interaction between segment 3 and segment 4 adjustments and dc level R332 adjustment.

- f. Turn SWEEP SELECTOR to OFF.
- g. Check power variation across the band. The power spread across the band should be no more than ± 1.5 db. If out of specifications re-touch segment potentiometers and dc level adjustment as needed.
- h. Turn FREQUENCY dial to low power point; RF LEVELER ON. With dc level potentiometer R332 increases cathode current to 1 ma greater than the value recorded in B1j.
- i. Replace meter plate with new meter plate, if meter plates do not agree.
- j. With the RF LEVELER in the OFF position, set balance R335 (figure 4-13) so that the power level is greater than 30 mw at low power point.

4-17. SERVICING THE SWEEP CIRCUITS.

A. VOLTAGES AND WAVESHAPES. The sweep circuit can be very difficult to service if definite conditions are not established. Figure 3-4 gives typical wave shapes and dc levels of the complete sweeping system. These voltages and wave shapes are the same for any speed of sweep. If the sweep rate is high, these wave shapes may be directly observed on a dc-coupled oscilloscope such as an $\text{\textcircled{hp}}$ Model 150A with a 10-megohm 10 pf probe such as an $\text{\textcircled{hp}}$ Model AC-21A. If this equipment is not available, it is possible to accurately measure the upper

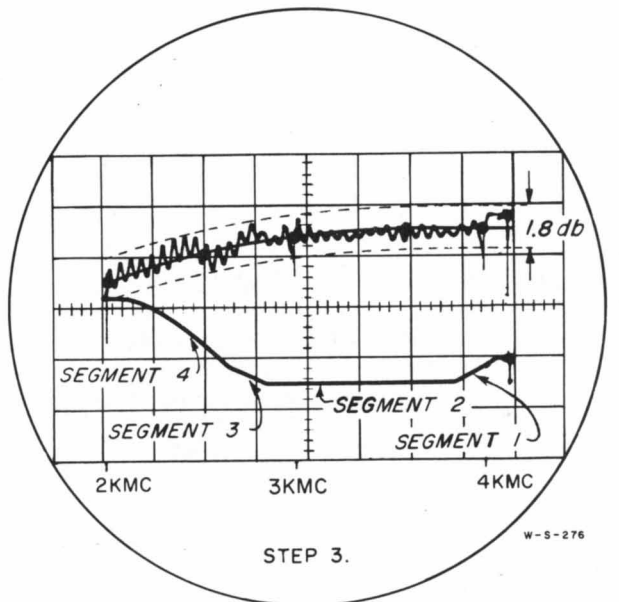
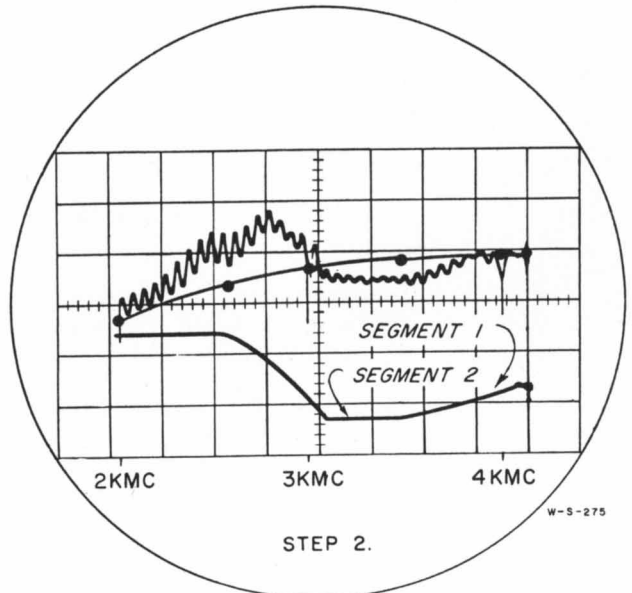
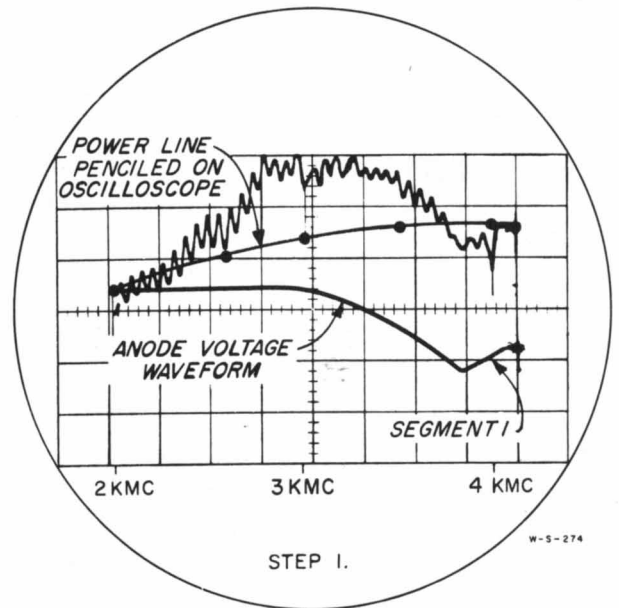

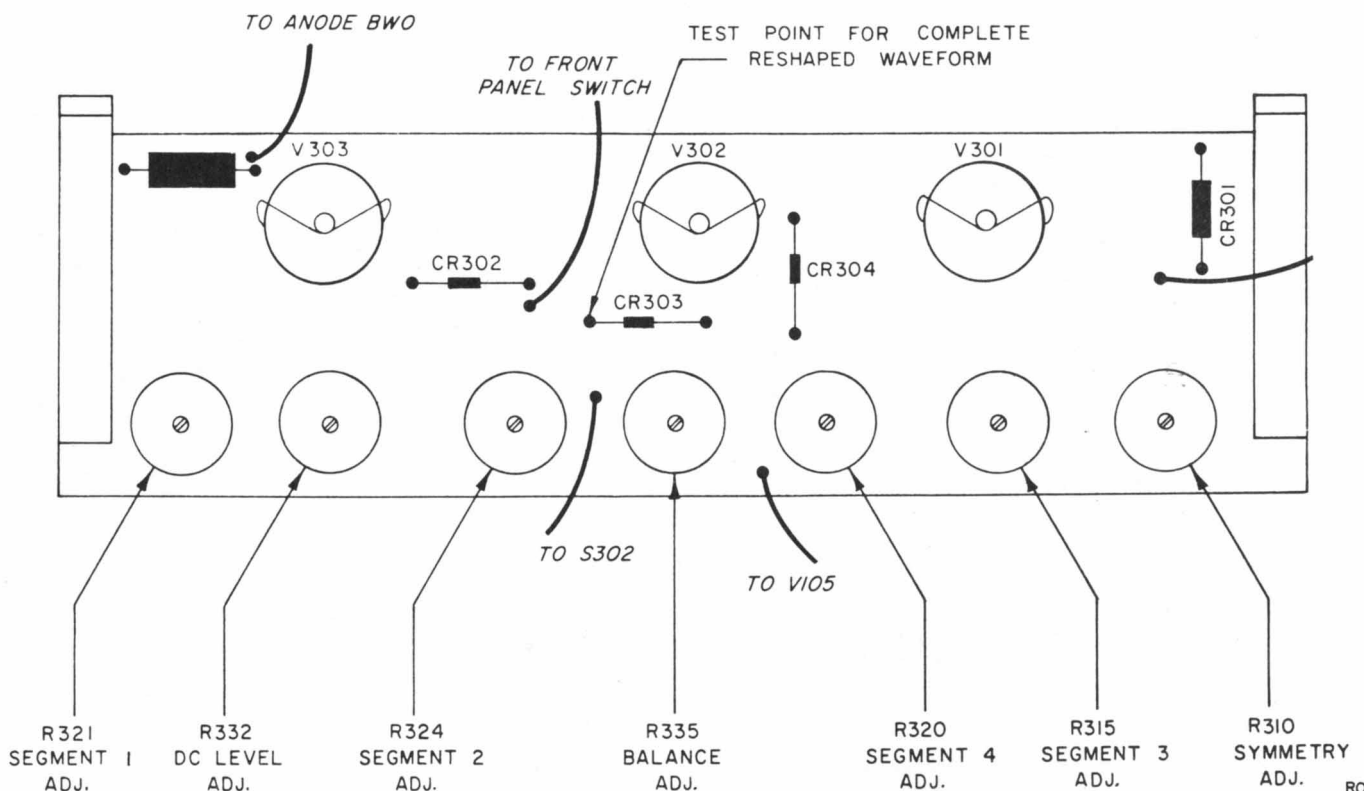

Figure 4-13. RF Leveler Circuit Board

and lower voltage limits by reducing the sweep rate to a very low value and using a vtvm with 122 megohms input impedance, such as an Φ Model 410B.

With the SWEEP SELECTOR in the TRIG. position, schmitt trigger V201 is biased to cut off the right-hand half. The voltage conditions in the circuits will then be those at t_1 on the waveforms. In a like manner, by temporarily connecting a jumper from pin 7 of V201 to the -150 volt bus, the schmitt trigger can be locked in the sweeping state. The voltages will then be those at time t_2 .

Note: The voltages shown (figures 3-4 and 4-21) across the coupling and switching diodes may appear, upon first observation, to be in error. The voltages given indicate that the diodes are conducting when the plate is slightly negative with respect to the cathode. This is correct. Thermionic diodes develop a contact potential between the plate and cathode of about 0.5 volt. For this reason, the diode actually starts to conduct when the plate is about -0.5 volt with respect to the cathode. The actual value of this voltage will change with cathode temperature. The heaters of critical tubes have regulated heater voltage to prevent a shift of sweep time calibration with changing line voltage. If the heater voltage is regulating at the wrong level the sweep circuit can be disabled. Paragraph 4-11 tells how to adjust the filament regulation.

B. SWEEP OUTPUT SAWTOOTH. The sawtooth voltage at the SWEEP OUTPUT jack (J203) is linear (see figures 4-6 and 4-17) and generally will not be

out of specifications. Should trouble be experienced, however, the points discussed below are among the possible sources.

Three troubles which may occur could cause a very distorted wave shape and thus can be easily detected. If V203 (6AL5) or V204 (6AN8) (figure 4-15) is defective, the sawtooth will be distorted. The defective tube generally has high heater-cathode leakage which modulates the sawtooth voltage. By observing the sawtooth SWEEP OUTPUT voltage on an oscilloscope distortion can easily be detected. Diode CR202 (figure 4-15) associated with the FREQUENCY potentiometer circuit will cause limiting on the sawtooth if the diode has a low front-to-back ratio. If diode CR201 (figure 4-15) is defective the V202B cathode will not follow the grid. The grid will then draw current which will disable the sweep circuit.

Note: G11A diodes in good condition typically will have a forward resistance of less than 100 ohms and a back resistance which is greater than 500,000 ohms. The actual resistance values read for diode CR201 or CR202 will vary with the internal voltage of the ohmmeter used. The above typical values are those read on an Φ Model 410B vtvm. The forward resistance is measured on the RX1 range and the back resistance on the RX1K or higher range.

If the sweep output voltage at J203 is too low or high, under approximately 20 volts or over approximately 27 volts, the schmitt trigger is probably not triggering reliably. This will also cause a nonlinear sweep. In this case V201 and/or V202A may be defective.

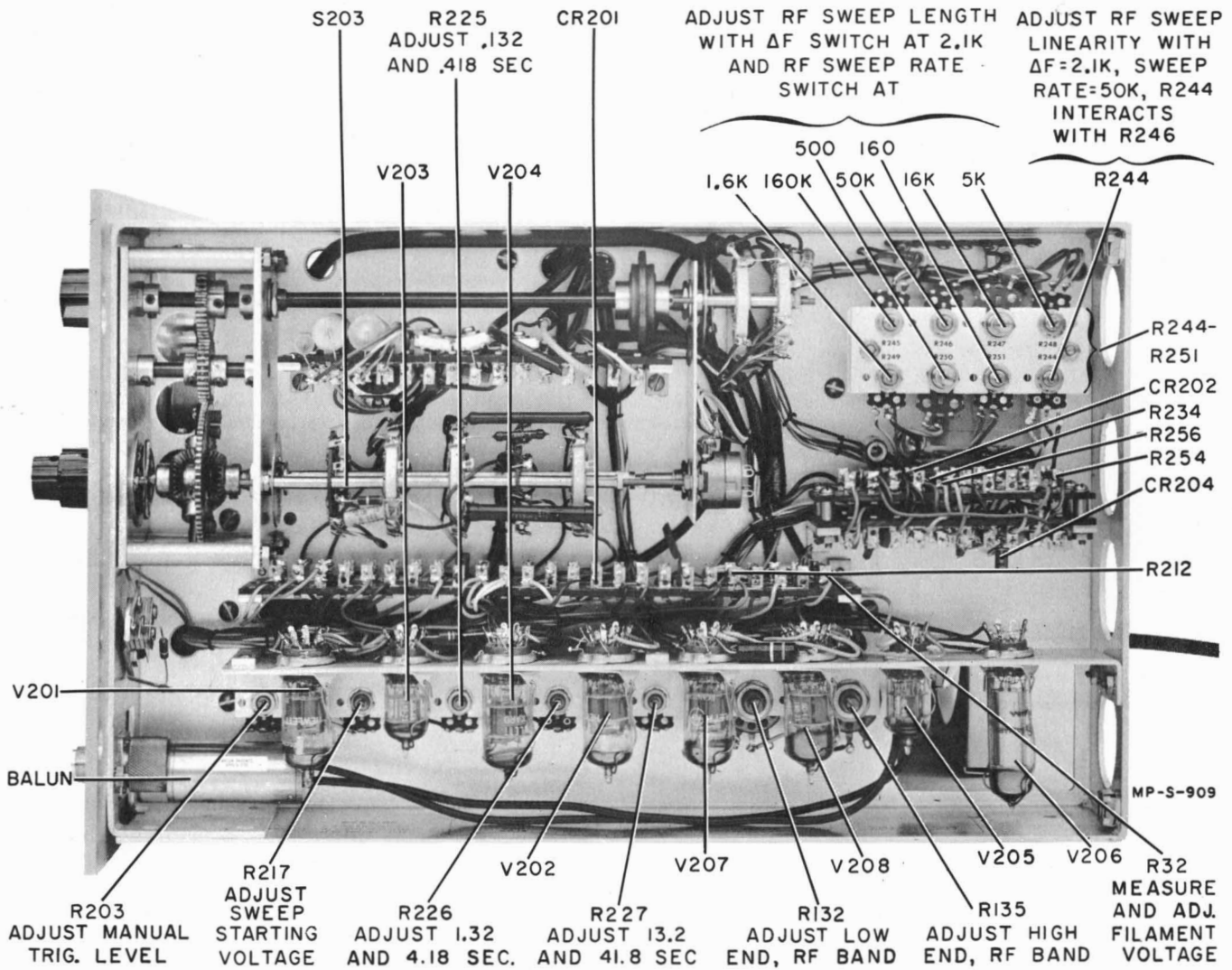

Figure 4-15. Model 683C Right Side View

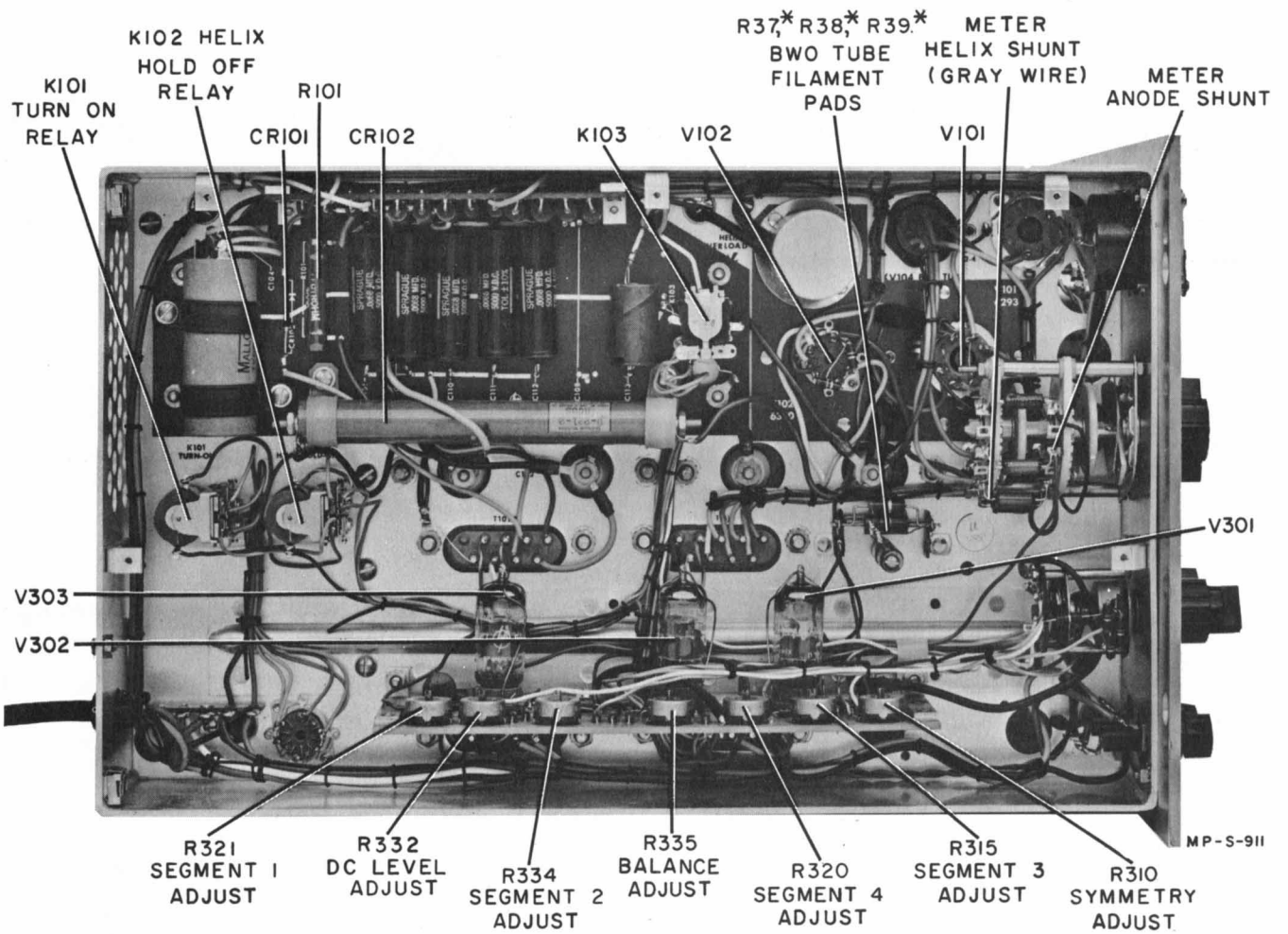

Figure 4-16. Model 683C Left Side View

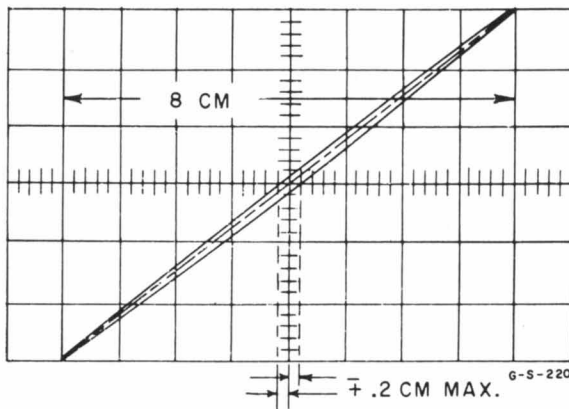

Figure 4-17. Sweep Output Voltage Linearity

- 3) Remove the long setscrew on the dial hub (do not touch the short setscrew!) and turn the FREQUENCY dial counterclockwise until it is stopped by the mechanical stop of the potentiometer rotor. Be careful not to use force.
- 4) Note the position of the dial with a pencil mark.
- 5) The two mechanical stops are in their proper relative location if the two pencil marks are 3/16 inch apart, measured on the edge of the dial.
- 6) To change the relative position of the two marks, release the short setscrew on the dial hub.
- 7) Hold the potentiometer shaft fixed in its counterclockwise position and turn the dial to the correct location with the vernier. Tighten the short setscrew.
- 8) Insert the long setscrew which provides the mechanical stop. The screw should hit before the internal stop in the potentiometer, both at full counterclockwise and full clockwise rotation.

B. POSITIONING FREQUENCY DIAL ON DIAL HUB.

The FREQUENCY dial must be properly positioned on the potentiometer shaft for correct frequency calibration. The dial is set at the factory and should never need resetting unless R236 is replaced.

To gain access to the FREQUENCY dial setscrews, loosen the two allen setscrews on the large black knob and slide the knob off the shaft.

Connect a low-range ohmmeter between the potentiometer wiper terminal (yellow lead) and the center-tap terminal (green lead). To position the potentiometer wiper at the center tap point, rotate the shaft until the ohmmeter reads a minimum (less than 1 ohm). Slip the FREQUENCY dial until the 3.1 kmc (gc) point is under the cursor. Carefully tighten the setscrews. Recheck the position by rocking the dial each side of the 3.1 kmc (gc) point. The minimum resistance reading must exactly agree with the 3.1 kmc (gc) mark. Reposition the dial on the shaft if necessary. Remove the ohmmeter and re-install the knob on the dial shaft.

4-20. TUBE REPLACEMENT.

In many cases instrument malfunction can be corrected by replacing a weak or defective tube. Before changing the setting of any internal adjustment, check the tubes. Adjustments that are made in an attempt to compensate for a defective tube will often complicate the repair problem.

It is good practice to check tubes by substitution rather than by using a "tube checker". The results obtained from the "tube checker" can be misleading. Before removing a tube, mark it so that if the tube is good it can be returned to the same socket. Replace only tubes proved to be weak or defective.

Except for the two tube, any standard tube with corresponding EIA (JEDEC) characteristics can be used as a replacement. Where variation in tube characteristics will affect circuit performance, an adjustment is provided. Table 4-1 lists the tests and adjustments which should be performed if such tubes are replaced.

4-21. TROUBLESHOOTING PROCEDURE.

The purpose of the troubleshooting chart (see figure 4-18) is 1) to provide a logical sequence for troubleshooting the 683C, 2) to isolate trouble to a circuit rather than to a component, and 3) to point out some of the more common troubles which might occur in the stage.

The troubleshooting chart is sectionalized by symptoms, as follows: 1) VERY LOW OR NO RF POWER OUTPUT, 2) NO SWEEP OUTPUT, 3) RF SWEEP JITTER AND/OR FREQUENCY SHIFT, 4) LOW RF POWER OUTPUT AND/OR EXCESSIVE POWER SPREAD, and 5) NO AMPLITUDE MODULATION.

Each section is divided into circuit blocks and trouble blocks. Circuit block represents a circuit in the 683C; the trouble block represents some common troubles that occur to a circuit block to which it is connected. Only those circuits to be checked and related troubles are included in each section. Arrowed solid lines indicate circuit relationships and signal direction between circuits. Dotted lines connect circuit blocks to trouble blocks. Where dotted lines extend from a circuit block in one section to a trouble block in another section, such troubles will be indicated by the symptoms which head the section in which the trouble block appears. To isolate the trouble causing the symptom, proceed in the order shown in that section.

As an aid in localizing the trouble within a section, a simplified trouble location procedure (see table 4-2) is included which gives step-by-step procedures for trouble isolation within a section.

Table 4-1. Tube Replacement Chart

Tube	Function	Standard Test or Adjustment
V104	Backward wave oscillator, figure 4-22	See paragraphs 4-11, 4-13
V201	Schmitt trigger, linear sweep time generator, figure 4-26	Adjust sweep time; see paragraph 4-12 Adjust schmitt trigger bias; see paragraph 4-17C
V204	Feedback integrator, linear sweep time generator, figure 4-26	Adjust sweep time; see paragraph 4-12
V207A	Control tube, helix supply reference voltage generator, figure 4-26	Check FREQUENCY dial setting; see paragraph 4-13C
V207B	Series regulator, helix supply reference voltage generator, figure 4-26	Check calibration adjustment pots (R245-251); paragraph 4-14, steps 1 through 12
V208	Differential amplifier, helix supply reference voltage generator, figure 4-26	Check calibration adjustment pots (R245-251); paragraph 4-14, steps 1 through 12
V301	Amplifier/square-wave generator, amplitude modulator, figure 4-24	Adjust square-wave symmetry R310; paragraph 4-15
V302 V303	RF leveler and reference anode circuit, figure 4-24	Adjust R332, paragraph 4-16

Table 4-2. Troubleshooting Procedure (Sheet 1 of 4)

SECTION I

VERY LOW OR NO RF OUTPUT POWER

Step 1. Low Voltage Power Supply.

A. -150 Volt Regulated Power Supply.

- 1) Check -150 volts. No -150 volts proceed as instructed below.
 - a. Remove primary power from 683C and measure resistance from -150 volt terminal (any white wire) to ground; should be approximately 33K ohms.
 - b. Check high voltage fuse (front panel).
 - c. Check voltage output across C121; should be approximately 420 volts. Possible trouble, CR105 and CR106. If not, continue to d.
 - d. Replace V107, V109, and V108 in that order.
 - e. Refer to paragraph 4-8 and calibrate the -150 volt power supply.

B. +300 Volt Regulated Power Supply.

Check +300 volts; no +300 volts proceed as instructed below.

- a. Remove primary power from 683C and measure resistance from +300 volt terminal to chassis ground; should be approximately 30K ohms.
- b. Apply power to the 683C and measure voltage across C119; should be approximately 450 volts. Possible trouble CR103 and CR104.
- c. Replace V106 and V107 in that order.
- d. Refer to paragraph 4-9 and calibrate the +300-volt power supply.

Step 2. Regulated Magnet Supply.

A. Magnet Current Check.

- 1) Rotate CURRENT selector to MAGNET.
- 2) After the 683C has been in operation for 5 minutes, read front panel meter; should read approximately 0.7 amp. If magnet current is very low (zero to 0.5 amp) proceed as instructed below.

B. Magnet Trouble Procedure.

- 1) Check magnet fuse (front panel). Check only if there is no magnet current.
- 2) Check voltage from pin 1, 5 of V3 (ground lead of dc vtvm) and pin 2, 5 of V1 (positive lead of dc vtvm); should be approximately +220 volts. Possible trouble CR1 or CR2.
- 3) Check voltage from pin 1, 5 of V3 (ground lead of dc vtvm) to pin 2, 4, 7 of V3 (positive lead of dc vtvm); should read approximately -150 volts. Possible trouble, CR3 or V3. Proceed to 4.
- 4) Replace V4 and V5.
- 5) Check neon lamps V6 through V11.
- 6) Refer to paragraph 4-7 to calibrate magnet circuit.

Step 3. Filament Circuit (R35).

- 1) Check filament voltage for V103, V105, V107, V109, V202, V207, V208, and V302. Place an ac vtvm across R32 (see figure 4-15, right side view); no 6.3 volts ac, replace R35.
- 2) Refer to paragraph 4-11 and calibrate filament circuit.

Step 4. Filament Circuit (R36).

Check filament voltage for V104 by placing an ac vtvm across parallel combination of R37, R38, R39 (see figure 4-16, left side view); no 6.3 volts ac, replace R36.

Step 5. High Voltage Supply.

Check high voltage between red lead, C103, and chassis ground. Voltage should be approximately 2500 volts. No voltage or very low voltage, check CR101.

Step 6. Collector Supply.

Replace V102.

Step 7. BWO Tube.

Refer to paragraph 4-13, Replacement of Backward-Wave Oscillator Tube and Calibration Procedure.

Table 4-2. Troubleshooting Procedure (Sheet 2 of 4)

SECTION II
NO RF SWEEP OUTPUTStep 1. Linear Sweep Generator.

- A. Check for 20-25 volt sawtooth at SWEEP OUTPUT jack (front panel).
- B. No sweep.
 - 1) Rotate SWEEP SELECTOR to RECUR.
 - 2) Rotate Δ FREQ. to 2.1K mc/sec.
 - 3) Rotate RF SWEEP MC/SEC to 160K.
 - 4) Connect a jumper between pin 2, V201 and -150 volts (reg.). This will disable the schmitt trigger.
 - 5) Check voltage at plate pin 7, V203; should be approximately -1.8 volts. Possible trouble: V204, V211.
 - 6) Check voltage at cathode, pin 1, V203; should be approximately +0.06 volt. If not, replace V203.
 - 7) Check voltage at grid, pin 8 of V204; should be approximately -1.8 volts. Possible trouble: V204, V211.
 - 8) Check voltage at cathode pin 1 of V204; should be approximately -1.2 volts. Possible trouble: V204, V211.
 - 9) Check voltage at plate pin 6, V204; should be approximately 63 volts. If not, replace V211 neon lamp.
 - 10) Check voltage at grid pin 2, V202; should be approximately -120 volts. If not, check voltage divider stick consisting of R212 and R213.
 - 11) Check voltage at cathode pin 8 of V202; should be approximately -0.35 volt. If not, adjust R217 and/or replace CR201.
 - 12) Remove jumper between pin 2, V201 and -150 volts.
 - 13) Refer to paragraphs 4-12 and 4-14 to calibrate sweep circuit.

Step 2. Helix Supply Reference Voltage Generator.

- 1) Check +150 volts between pin 1, 5 of V206 and ground. Possible trouble: V206.
- 2) Rotate SWEEP SELECTOR to RECUR.
- 3) Check exponential waveform with oscilloscope at pin 2, V105. No exponential sweep, proceed as instructed below.
- 4) Rotate SWEEP SELECTOR to OFF.
- 5) Connect a dc vtvm (+150 volt range) between pin 8, V207 and ground. Rotate FREQUENCY dial; voltage should vary with FREQUENCY dial variation. Possible trouble: R236.
- 6) Place dc vtvm (+300 volt range) between pin 6, V207 and ground. Rotate FREQUENCY dial; voltage at pin 6 of V207 should follow FREQUENCY dial variation. Possible trouble: V207, V205, CR204.
- 7) Refer to paragraph 4-14 and calibrate sweep length.

Step 3. Regulated Helix Supply.

- 1) SWEEP SELECTOR to OFF.
- 2) Connect a dc vtvm, with a range between 200 to 2500 volts, from pins 1, 4, 8 of V101 to ground and rotate FREQUENCY dial from 2 to 4 kmc (gc). Voltage variation should be approximately 350 to 2200 volts. Possible trouble: V103, V105, V110, C114.

DANGER: High voltage; remove primary power before making connections.

- 3) Refer to paragraph 4-13C and calibrate FREQUENCY dial.

Table 4-2. Troubleshooting Procedure (Sheet 3 of 4)

SECTION III

RF JITTER AND/OR FREQUENCY SHIFT

Step 1. Low Voltage Power Supply.

A. -150 Volt Power Supply.

1) RF Jitter:

- a. Connect an ac vtm between ground and -150 volt terminal (any white wire) in power supply.
- b. If ripple voltage exceeds 3 millivolts, possible trouble: V108, V109.

2) Frequency Shift:

- a. Place a dc vtm between ground and -150 volt terminal (any white wire) and vary power line voltage from 103 to 127 volts. If -150 volts varies, replace V107 and V109.
- b. Refer to paragraph 4-8 and calibrate -150 volt supply.

B. +300 Volt Supply.

1) RF Jitter:

- a. Connect an ac vtm between +300 volts (any solid red lead) and ground. If ripple voltage exceeds 10 millivolts, replace V107 and V109.
- b. Refer to paragraph 4-9 and calibrate +300 volt supply.

Step 2. Regulated Magnet Supply.

A. RF Jitter:

- 1) Connect a floating ac vtm with its ground lead at pins 1 and 5 of V3 and its positive lead to one side of R40.
- 2) Vary power line voltage from 103 to 127 volts ac and observe ripple voltage on ac vtm.
- 3) If ripple voltage exceeds 100 millivolts, possible trouble: V5, V6 through V11.

Note: In the case of the neon lamps V6 through V11, the faulty neon lamp can be isolated by shunting a 470K resistor across each neon while watching the ripple indication of the ac vtm. When ripple indication on ac vtm dips the faulty neon lamp has been isolated and should be replaced.

4) Refer to paragraph 4-7 and calibrate magnet power supply.

B. Frequency Shift:

- 1) Rotate CURRENT selector to MAGNET.

2) Vary power line voltage from 103 to 127 volts ac. Magnet current should not vary more than ± 0.25 ampere. Allow time for the magnet supply to settle before the power line voltage is changed and current reading is taken.

3) Possible trouble: control tube -V5 or neon lamps V6 through V11.

4) Refer to paragraph 4-7 and calibrate magnet supply.

Step 3. Linear Sweep Generator.

A. RF Jitter:

1) Connect oscilloscope to SWEEP OUTPUT jack; SWEEP SELECTOR to RECUR.

2) Check sawtooth displayed on oscilloscope for jitter. If jitter is present, possible trouble: V203, V211, V209, V210 in that order.

B. RF Frequency Shift:

The linear sweep generator should not cause frequency shift and can be eliminated as a possible source of trouble. Proceed to next step.

Step 4. Exponential Sweep Generator.

A. RF Jitter:

1) 683C front panel settings:

SWEEP SELECTOR	RECUR
Δ FREQ.	2.1 kmc (gc)
SWEEP RATE	160K
AMPL. MOD. SELECTOR	OFF
FREQUENCY dial	4.0 kmc (gc)

2) Connect oscilloscope probe from pin 5, V205 and observe exponential waveform. If there is jitter of the exponential sweep, possible trouble: CR204, V206, V207, V208, V209.

B. Frequency Shift:

The exponential sweep generator should not cause momentary frequency shifts; thus the circuit can be eliminated as a possible frequency shift trouble. Proceed to next step.

Step 5. Regulated Helix Supply.

A. RF Jitter:

1) Front panel control settings same as in step 4A1.

2) Place oscilloscope probe at pin 1, V105 and observe exponential waveform on oscilloscope. If there is jitter of the exponential sweep, possible trouble: V105, V103, V110, L101 in that order.

Table 4-2. Troubleshooting Procedure (Sheet 4 of 4)

SECTION IV

LOW POWER OUTPUT AND/OR EXCESSIVE POWER SPREAD

Step 1. Reference Anode Circuit.

A. Low Power.

1) Adjust dc level adj. R332 to obtain minimum of 30 milliwatts at low power point. See paragraph 4-16 and calibrate rf leveler circuit.

2) Replace two tube; refer to paragraph 4-13.

B. Excessive Power Spread.

Connect an oscilloscope to the output of cathode follower V303B and observe waveform. Vary segment 1, 2, 3, 4 adjusts. Each segment should vary as its adjustment is varied. If not, possible trouble: CR302, CR303, CR304.

SECTION V

AMPLITUDE MODULATION

A. Set the SWEEP SELECTOR to OFF.

B. Rotate MOD. SELECTOR to all three modulating positions. INT., PULSE and EXT., applying an external signal where appropriate. If there is no modulation output for all positions of the AMPL. MOD. SELECTOR, possible trouble: CR301, V301. Refer to paragraph 4-15 and calibrate circuit.

C. Rotate AMPL. MOD. SELECTOR to INT.; no square-wave output. Possible trouble: V301, C302, S301.

D. No PULSE modulation, all other modulation positions operating normally. Possible trouble: S301.

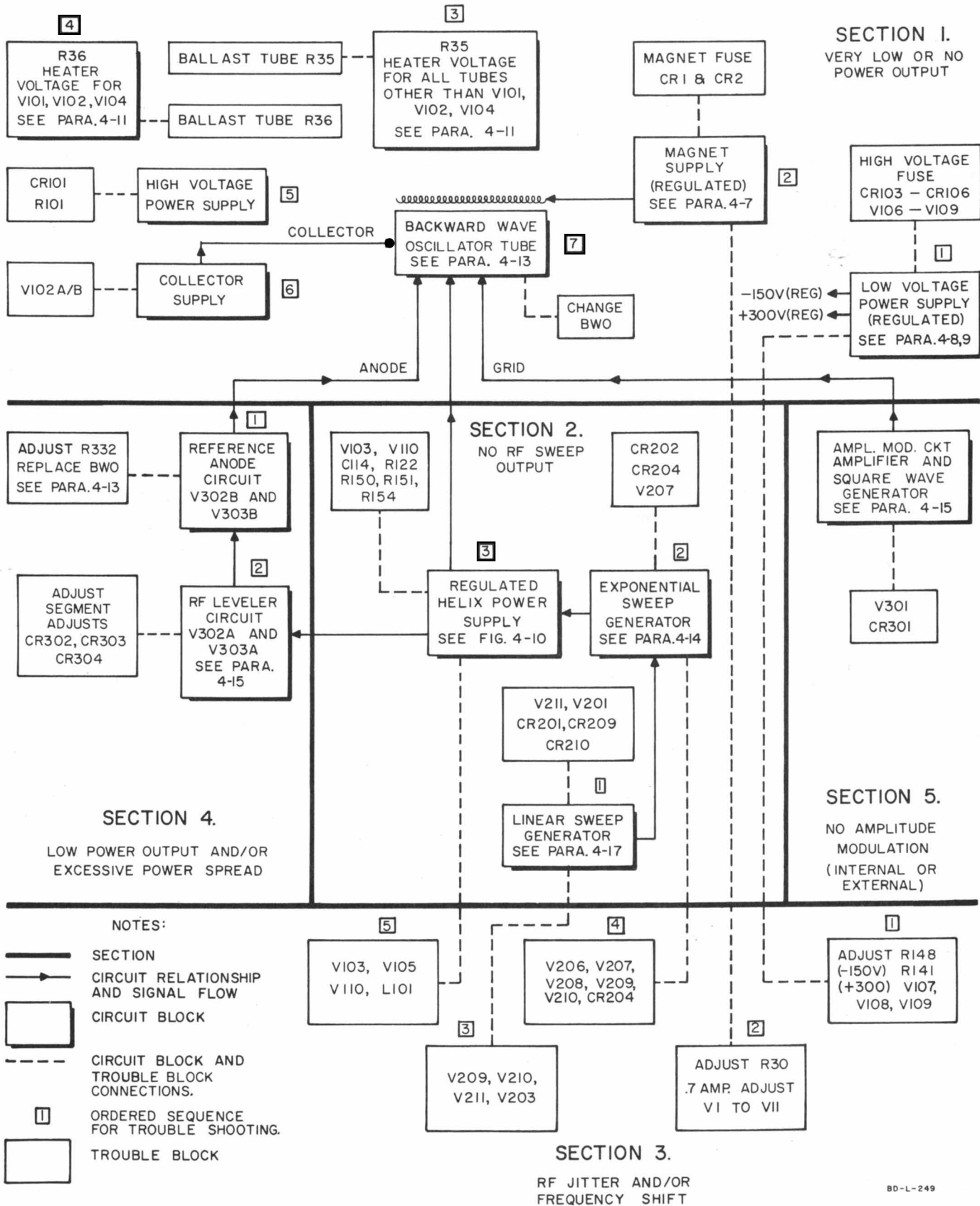

Figure 4-18. Troubleshooting Chart

SCHEMATIC DIAGRAM NOTES

1. Heavy box indicates front-panel engraving.
2. Resistance values in ohms, inductance in microhenries, and capacitance in picofarads unless otherwise specified.
3. Relays shown in de-energized position.
4. (*) Indicates a padded resistor, electrical value adjusted at factory. Average value shown.

VOLTAGE AND RESISTANCE DIAGRAM NOTES

1. Voltage values shown with an (*) are for guidance. Values may vary from those shown, due to tube aging or normal differences between instruments. Resistance values may vary considerably from those shown when the circuit contains potentiometers, crystal diodes, or electrolytic capacitors.
2. A solid line between socket terminals indicates a connection external to the tube between the terminals; a dotted line between terminals indicates a connection inside the tube. Voltage and resistance are given at only one of the two joined terminals.
3. Unless otherwise specified, dc and resistance measurements made with an hp Model 410B VT-VOM (122 megohms input impedance), common lead connected to chassis. DC voltages over 1000 volts measured with an hp Model 459A, 100:1 multiplier probe of 12,000 megohms input resistance.
4. AC voltage, except ripple measurements, made with multimeter of 5000 ohms-per-volt sensitivity $\pm 2\%$ accuracy. Ripple measurements made with hp Model 400D AC-VTVM (0.001V fs max sensitivity, 10 megohms input impedance).
5. Instrument operating under cw conditions at 3 kmc (gc). CATHODE current at value marked on meter panel.
6. Resistance measurements made with all controls full counterclockwise and FREQUENCY dial at 3 kmc (gc).

POWER SUPPLY TURN-ON SEQUENCE OF OPERATIONS

1. Closing front panel switch S101 applies 115 volts ac through F101 to magnet supply rectifier/doubler. The return path from C1 and C2 is through T101 6-volt winding (A6-A5) to T1 terminal (A2) to other side of power line.
 - In addition, closing S101 applies power to T1, fan B101, and to the heater of thermal time delay switch S102. The circuit to S102 heater is from T1 (A3) through back contacts of K101, K102, through heater and back to T1 (A4).
 - Thermal time delay switch S102 operates after 60 seconds, completing circuit to K101 coil: from T1 6-volt winding (A7), through K101 coil, S102 contacts, K102 back contacts to T1 (A8).
 - Delayed turn-on relay K101 operates and 1) breaks circuit to S102 heater, 2) completes circuit to T101 primary, and 3) closes holding contacts in parallel with S102 contacts to keep K101 energized after S102 cools off.
- Instrument is now fully energized.

OVERLOAD PROTECTION OPERATION

1. Excessive current (approximately 3.0 ma) through coil of helix overload relay K103 causes it to operate and in turn close circuit to K102 coil.
- 2) K102 then 1) breaks circuit to K101 which de-energizes and disconnects power from T101 primary winding, 2) opens operating circuit to S102 heater, and 3) closes holding contacts in parallel with K103 contacts to keep K102 energized.

High voltage circuits energized from T101 are now disabled.

To reset the overload circuits, momentarily turn off main power switch S101. With power off, T1 and K102 de-energized, and K102 closes its back contacts to prepare the operating circuit to time delay switch S102 and delayed turn-on relay K101.

Power supply delayed turn-on circuits will recycle as soon as S101 is again turned on.

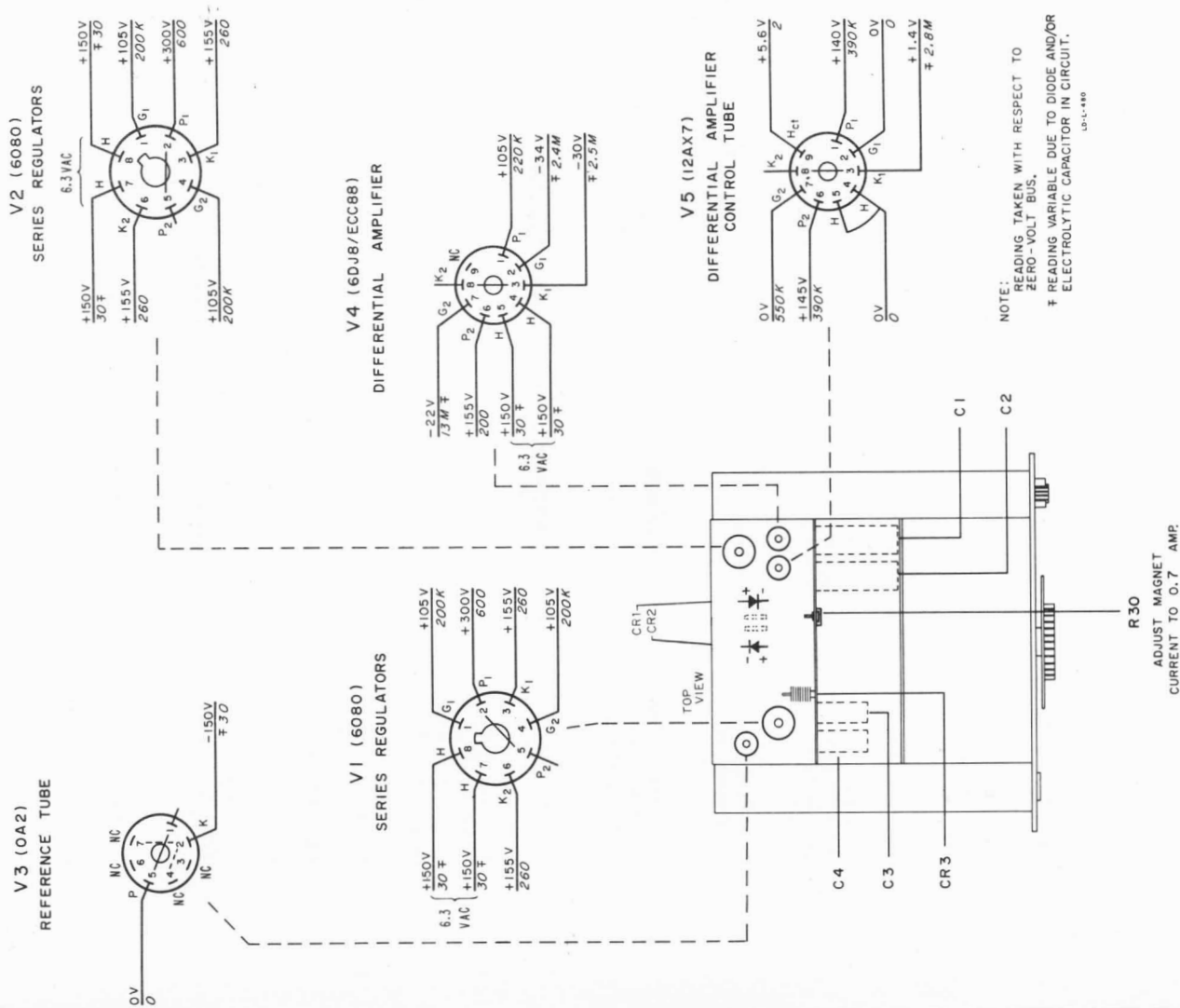
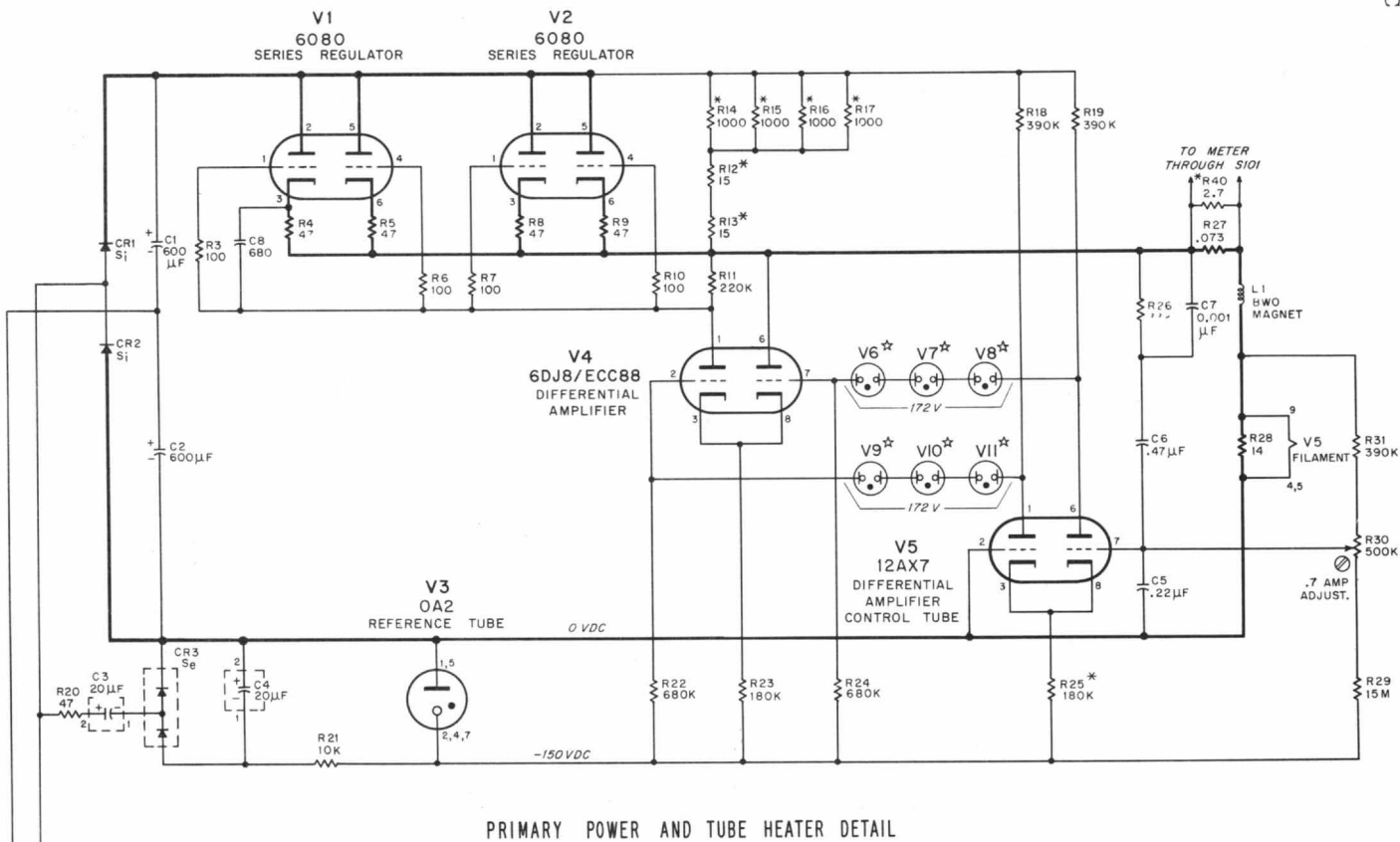
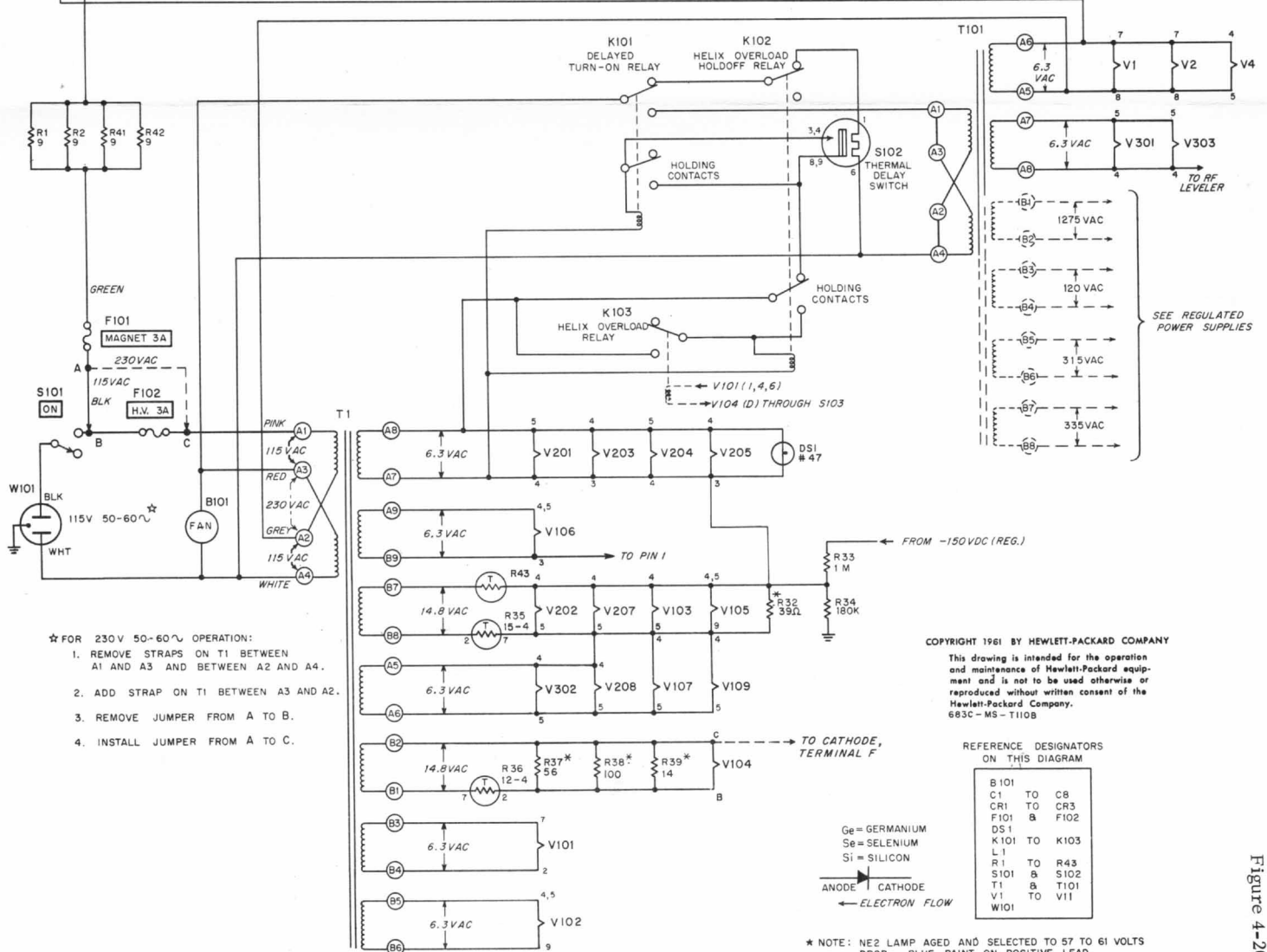

Figure 4-19. Magnet Power Supply (Current Regulated)

BWO MAGNET CURRENT REGULATOR



PRIMARY POWER AND TUBE HEATER DETAIL



- ★ FOR 230V 50-60~ OPERATION:
1. REMOVE STRAPS ON T1 BETWEEN A1 AND A3 AND BETWEEN A2 AND A4.
 2. ADD STRAP ON T1 BETWEEN A3 AND A2.
 3. REMOVE JUMPER FROM A TO B.
 4. INSTALL JUMPER FROM A TO C.

COPYRIGHT 1961 BY HEWLETT-PACKARD COMPANY
 This drawing is intended for the operation and maintenance of Hewlett-Packard equipment and is not to be used otherwise or reproduced without written consent of the Hewlett-Packard Company.
 683C-MS-T110B

REFERENCE DESIGNATORS ON THIS DIAGRAM

B101	TO C8
C1	TO C8
CR1	TO CR3
F101 & F102	
DS1	
K101 TO K103	
L1	
R1	TO R43
S101 & S102	
T1	
V1	TO V11
W101	

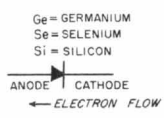

★ NOTE: NE2 LAMP AGED AND SELECTED TO 57 TO 61 VOLTS DROP. BLUE PAINT ON POSITIVE LEAD.

Figure 4-20. Regulated Primary Power and Magnet Current Supply

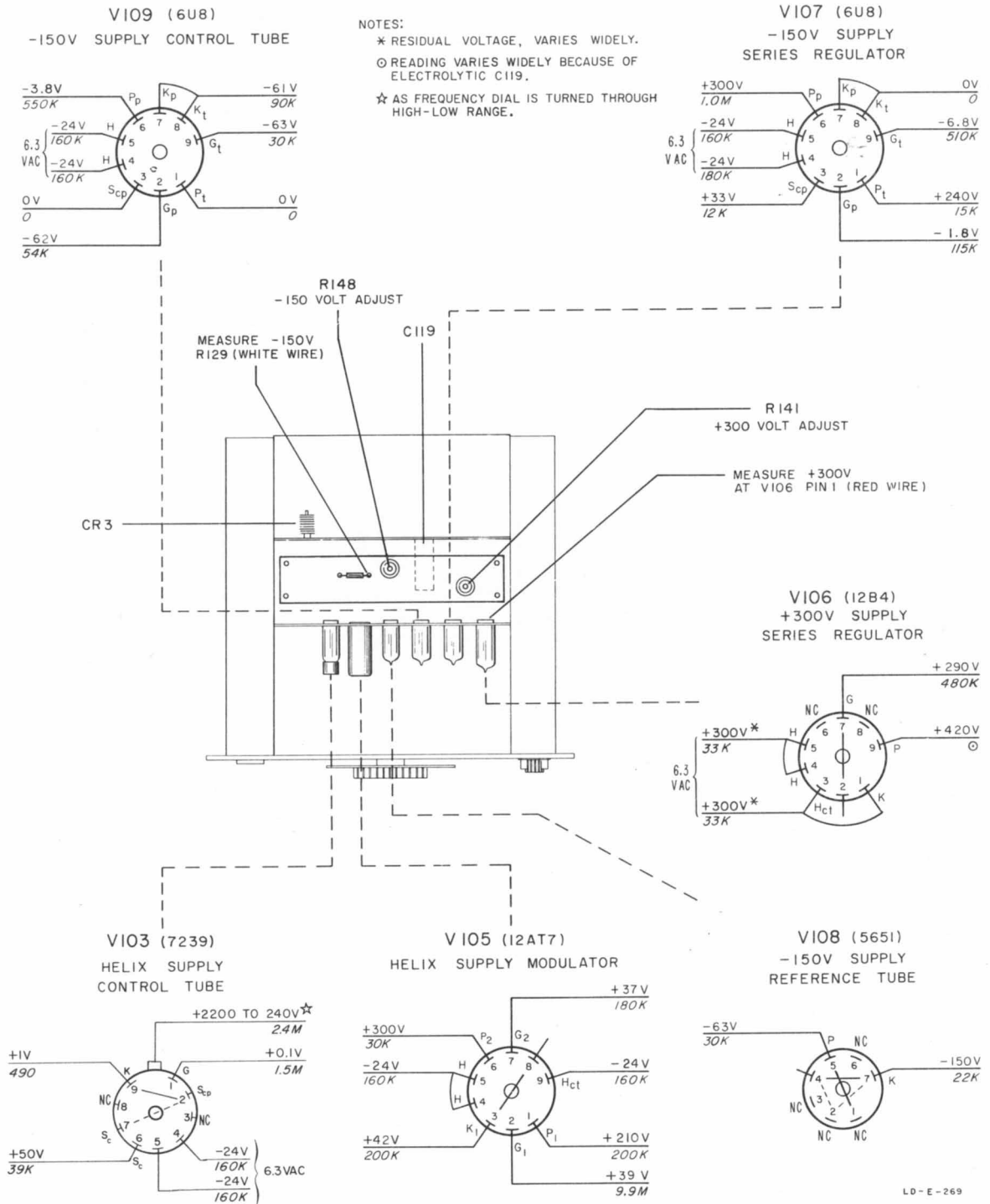
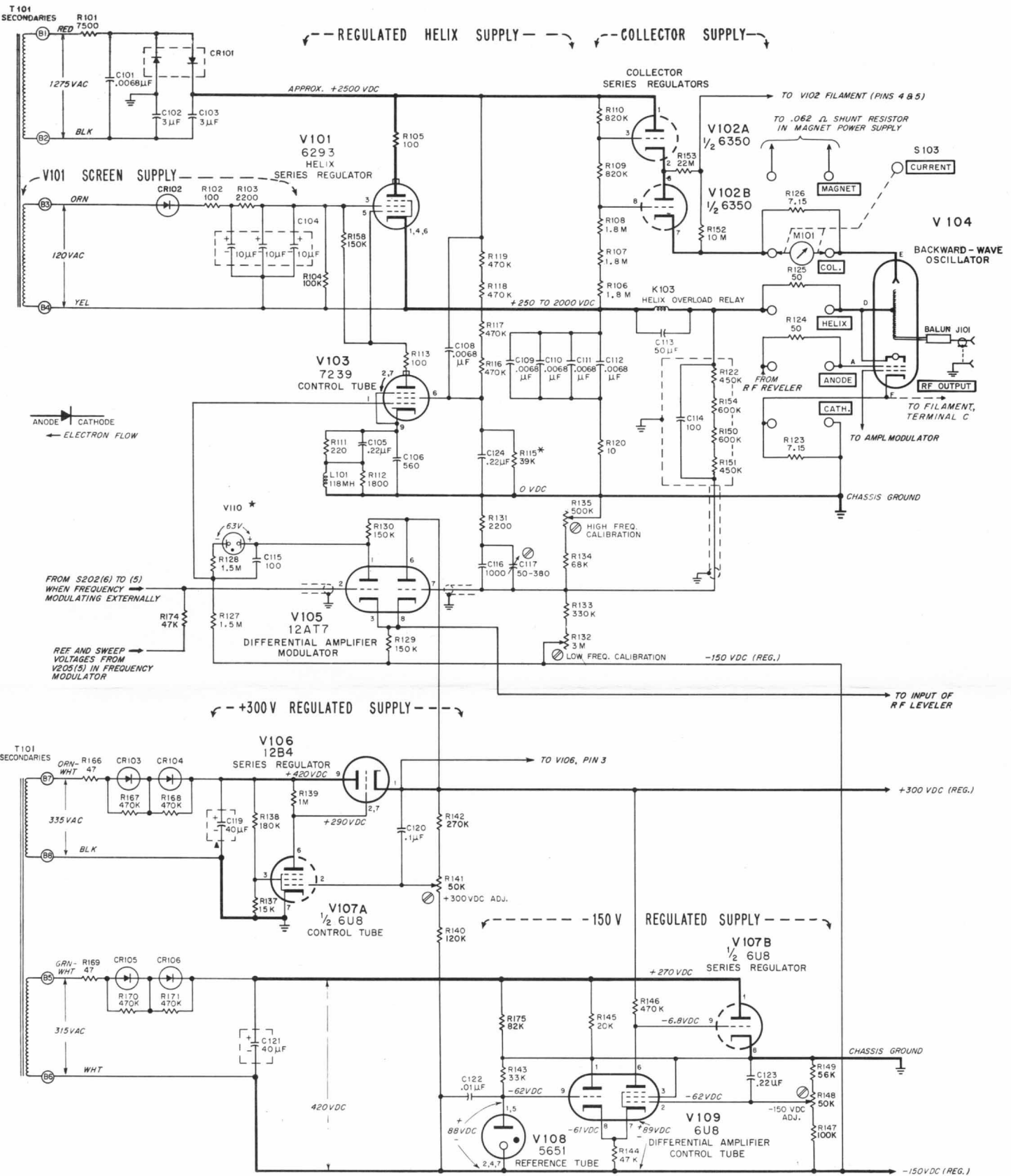

Figure 4-21. Regulated +300 and -150 Volt Power Supplies



REFERENCE DESIGNATORS ON THIS DIAGRAM

- C101 TO C124
- CR101 TO CR106
- J101
- L101
- R101 TO R171, R174, R175
- S103
- V101 TO V110
- M101

NOTES:

SEE PRIMARY POWER & MAGNET CURRENT SUPPLY DWG. FOR B101, F101, F102, K101, K102, K103, S101, S102, W101 AND PART OF T101.

*NE2 LAMP AGED AND SELECTED FOR 61 TO 65V DROP; RED PAINT ON POSITIVE LEAD.

UNASSIGNED:
R121, 114, 155-157, 159-165, R136
C107, C118,

COPYRIGHT 1961 BY HEWLETT-PACKARD COMPANY
This drawing is intended for the operation and maintenance of Hewlett-Packard equipment and is not to be used otherwise or reproduced without written consent of the Hewlett-Packard Company.
683C REF. DS-T110

Section IV
Figure 4-23

Model 683C

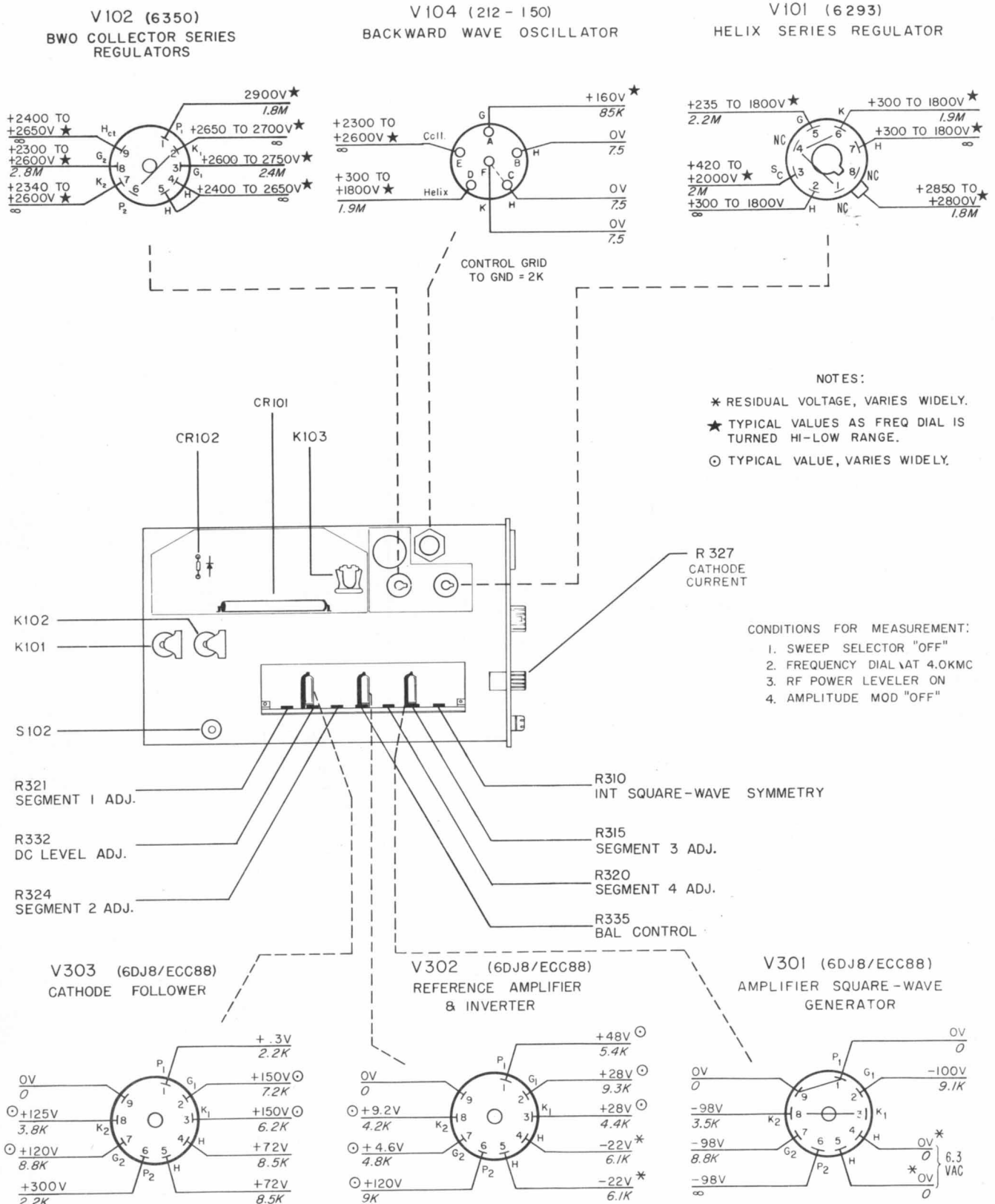
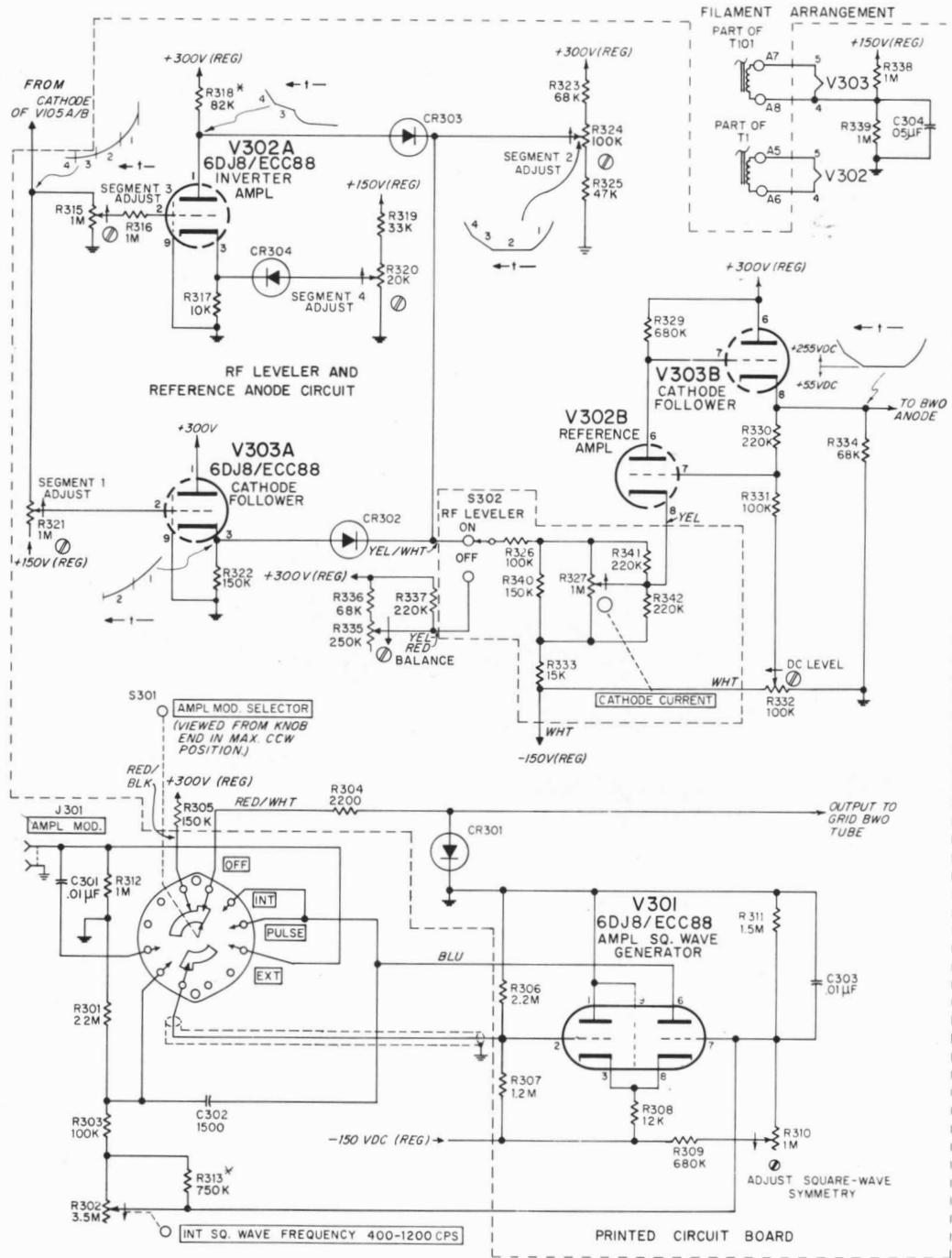

Figure 4-23. RF Power Leveler and Amplitude Modulator



AMPL MODULATION AND ANODE SECTION

COPYRIGHT 1960 BY HEWLETT-PACKARD COMPANY

This drawing is intended for the operation and maintenance of Hewlett-Packard equipment and is not to be used otherwise or reproduced without written consent of the Hewlett-Packard Company.
683C-AMPL. MOD. AND ANODE SEC. T10B

REFERENCE DESIGNATORS

C301 - C304
CR301 - CR304
J301
R301 - R313, R315 - R327, R329 - R342
S301, S302
V301 - V303

Figure 4-24. Amplitude Modulator and Anode Section

Section IV
Figure 4-25

Model 683C

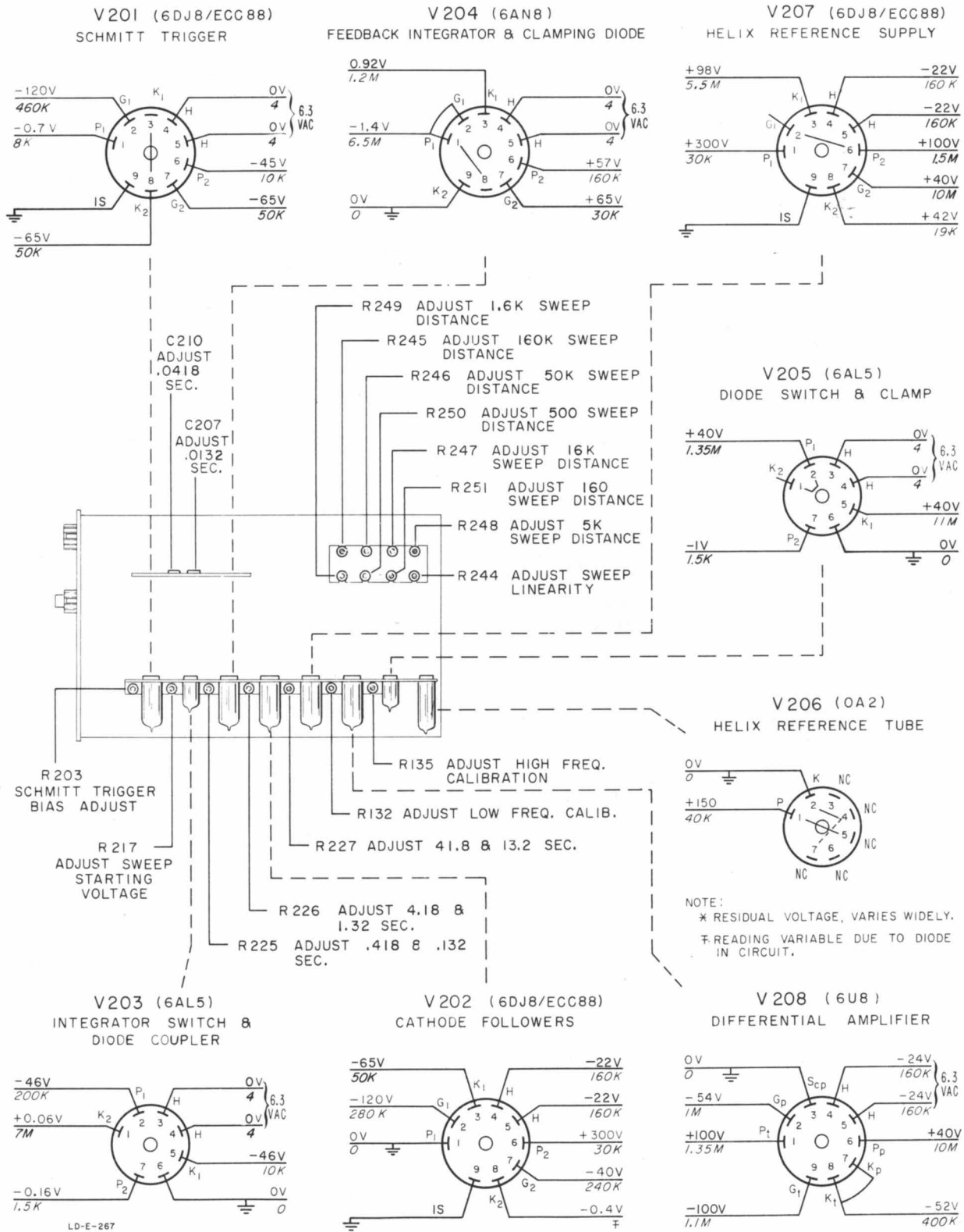

Figure 4-25. Exponential and Linear Sweep Generators

EXPONENTIAL HELIX SWEEP GENERATOR

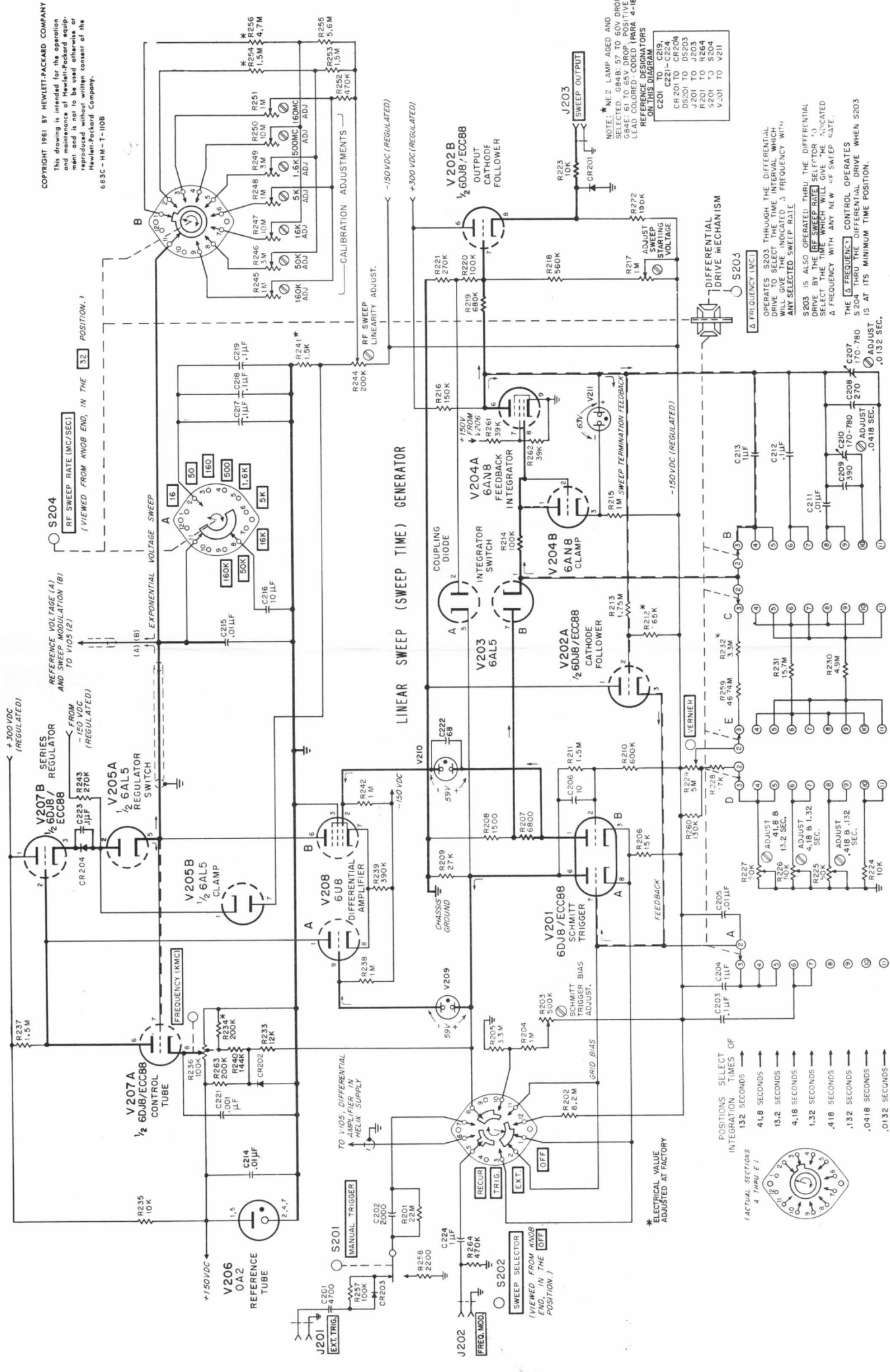







Figure 4-26. Frequency (Helix) Modulator

WARRANTY CLAIM AND ADJUSTMENT PROCEDURE

for microwave tubes supplied by the
HEWLETT-PACKARD COMPANY
for use in  instruments

Microwave tubes supplied by the Hewlett-Packard Company, either as original or replacement, for use in  instruments are actually warranted by the tube manufacturer and not by . However,  will process warranty claims for you, and will promptly pass on all allowances granted by the tube manufacturer.

In the event that your tube is found to be repairable, the tube manufacturer reserves the right to repair and return the tube in lieu of issuing pro-rata credit.

For your convenience, warranty claims for all microwave tubes supplied by the Hewlett-Packard Company may be made on this single form; merely fill out the information on the reverse side and return this form, along with the defective tube, to your  engineering representative, or to . Please be sure each space on the form is filled in--lack of complete information may delay processing of your claim.

Each tube manufacturer has his own warranty policy. Copies of individual Conditions of Warranty are available from your  engineering representative or from the Hewlett-Packard Company.

SHIPPING INSTRUCTIONS

The following instructions are included to aid you in preventing damage in transit. Package your tube carefully -- no allowance can be made on broken tubes.

1. Carefully wrap tube in 1/4 inch thick "kimpack", cotton batting, or other soft padding material.
2. Wrap the above in heavy kraft paper.
3. Pack in a rigid container which is at least 4 inches larger than the tube in each dimension.
4. Surround the tube with at least 2 inches of shock absorbing material. Be certain that the packing is tight all around the tube.
5. Tubes returned from outside the continental United States should be packed in a wooden box.
6. Mark container FRAGILE and ship prepaid via Air Freight or Railway Express. Do not ship via Parcel Post or Air Parcel Post since experience has shown that fragile items are more apt to be damaged when shipped by these means.

Tubes returned to the Hewlett-Packard Company should be addressed to:

CUSTOMER SERVICE

Hewlett-Packard Company
395 Page Mill Road
Palo Alto, California, U.S.A.

OR (In Western Europe)

Hewlett-Packard S.A.
Rue du Vieux Billard No. 1
Geneva, Switzerland

MICROWAVE TUBE WARRANTY CLAIM
INFORMATION FORM

IMPORTANT: Please answer all questions fully -- insufficient information may delay processing of your claim.

FROM: (Tube Owner)

Date _____

Company _____

FOR FURTHER INFORMATION CONTACT:

Address _____

Name _____

Title _____

Company _____

Tube type _____

Address _____

Tube serial No. _____

Tube mfr. _____

Tube purchased from _____

Use in ^{hp} Model _____

Instrument serial no. _____

On P. O. number _____

Tube is Original () or Replacement ()

Date tube received _____

Hours use per day (average) _____

Date first tested _____

Number of days in service _____

Date placed in service _____

Total hours filament operation _____

Date of failure _____

SYMPTOMS: (Please describe conditions prior to and at time of failure, along with description of tube's defect, if known) _____

Were there other circuit component failures at time of failure? Which ones?

Signature _____

Title _____

SECTION V

REPLACEABLE PARTS

5-1. INTRODUCTION.

This section contains information for ordering replacement parts for the Model 683C Sweep Oscillator.

Table 5-1 lists replaceable parts in alpha-numerical order of their reference designators. Detailed information on a part used more than once in the instrument is listed opposite the first reference designator applying to the part. Other reference designators applying to the same part refer to the initial designator. Miscellaneous parts are included at the end of the list. Detailed information includes the following:

- 1) Reference designator.
- 2) Full description of the part.
- 3) Manufacturer of the part in a five-digit code; see list of manufacturers in appendix.
- 4) Hewlett-Packard stock number.
- 5) Total quantity used in the instrument (TQ column).
- 6) Recommended spare quantity for complete maintenance during one year of isolated service (RS col).

5-2. ORDERING INFORMATION.

To order a replacement part, address order or inquiry either to your authorized Hewlett-Packard sales representative or to

CUSTOMER SERVICE -
Hewlett-Packard Company
395 Page Mill Road
Palo Alto, California

or, in Western Europe, to

Hewlett-Packard S. A.
Rue du Vieux Billard No. 1
Geneva, Switzerland

Specify the following information for each part:

- 1) Model and complete serial number of instrument.
- 2) Hewlett-Packard stock number.
- 3) Circuit reference designator.
- 4) Description.

To order a part not listed in table 5-1, give description of the part and include its function and location.

Table 5-1. Replaceable Parts

Ckt Ref.	Description	Mfr	hp Stock No.	TQ	RS		
B101	Fan Motor	06812	3140-0011	1	1		
	Fan Blade	06812	3160-0015	1	1		
C1,2	Capacitor: fixed, electrolytic, 600 μ f, 200 vdcw	56289	0180-0046	2	1		
C3,4	Capacitor: fixed, electrolytic, 20 μ f, 450 vdcw	56289	0180-0011	2	1		
C5	Capacitor: fixed, paper, 0.22 μ f \pm 10%, 400 vdcw	56289	0160-0018	1	1		
C6	Capacitor: fixed, paper, 0.47 μ f \pm 10%, 200 vdcw	56289	0160-0015	1	1		
C7	Capacitor: fixed, mica, 0.001 μ f \pm 10%, 500 vdcw	76433	0140-0003	1	1		
C8	Capacitor: fixed, mica, 680 pf \pm 10%, 500 vdcw	00853	0140-0007	1	1		

Table 5-1. Replaceable Parts (Cont'd)

Ckt Ref.	Description	Mfr *	Ⓢ Stock No.	TQ*	RS*		
C9 thru C100	Not assigned						
C101	Capacitor: fixed, paper, 6800 pf ± 10%, 5000 vdcw	56289	0160-0045	6	2		
C102, 103	Capacitor: fixed, paper, 3 μf + 20% - 10%, 2000 vdcw	00853	0160-0083	2	1		
C104	Capacitor: fixed, electrolytic, 3 sections, 10 μf/section, 450 vdcw	37942	0180-0016	1	1		
C105	Capacitor: fixed, mylar, 0.22 μf ± 10%, 200 vdcw	56289	0170-0038	3	1		
C106	Capacitor: fixed, mica, 560 pf ± 10%, 500 vdcw	00853	0140-0044	1	1		
C107	Not assigned						
C108 thru C112	Same as C101						
C113	Capacitor: fixed, electrolytic, 50 μf - 10% + 200%, 50 vdcw	37942	0180-0029	1	1		
C114	Capacitor: fixed, ceramic, 100 pf ± 5%, 4000 vdcw	91418	0150-0049	1	1		
C115	Capacitor: fixed, mica, 100 pf ± 10%, 500 vdcw	00853	0140-0054	1	1		
C116	Capacitor: fixed, paper, 0.001 μf ± 10%, 600 vdcw	56289	0160-0006	2	1		
C117	Capacitor: variable, mica, 50-380 pf, 175 vdcw	72136	0131-0001	1	1		
C118	Not assigned						
C119	Capacitor: fixed, electrolytic, 40 μf, 450 vdcw	56289	0180-0024	2	1		
C120	Capacitor: fixed, paper, 0.1 μf ± 10%, 400 vdcw	56289	0160-0013	1	1		
C121	Same as C119						
C122	Capacitor: fixed, paper, 0.01 μf ± 20%, 400 vdcw	56289	0160-0054	3	1		
C123, 124	Same as C105						
C125 thru C200	Not assigned						
C201	Capacitor: fixed, mylar, 4700 pf ± 10%, 400 vdcw	84411	0170-0021	1	1		

* See introduction to this section

Table 5-1. Replaceable Parts (Cont'd)

Ckt Ref.	Description	Mfr *	Ⓜ Stock No.	TQ*	RS*		
C202	Capacitor: fixed, ceramic, 2000 pf \pm 20%, 1000 vdcw	91418	0150-0023	1	1		
C203	Capacitor: fixed, mylar, 0.1 μ f \pm 5%, 200 vdcw	84411	0170-0019	5	2		
C204	Capacitor: fixed, mylar, 1 μ f \pm 5%, 200 vdcw	84411	0170-0018	3	1		
C205	Capacitor: fixed, mylar, 0.01 μ f \pm 5%, 400 vdcw	84411	0170-0017	4	1		
C206	Capacitor: fixed, mica, 10 pf \pm 10%, 500 vdcw	76433	0140-0002	1	1		
C207	Capacitor: variable, mica, 170-780 pf, 175 vdcw	72136	0131-0003	2	1		
C208	Capacitor: fixed, mica, 270 pf \pm 10%, 500 vdcw	00853	0140-0015	1	1		
C209	Capacitor: fixed, mica, 390 pf \pm 10%, 500 vdcw	76433	0140-0030	1	1		
C210	Same as C207						
C211	Same as C205						
C212	Same as C203						
C213	Same as C204						
C214, 215	Same as C205						
C216	Capacitor: fixed, mylar, 10 μ f \pm 5%, 200 vdcw	72928	0170-0025	1	1		
C217 thru C219	Same as C203						
C220	Not assigned						
C221	Same as C116						
C222	Capacitor: fixed, mica, 68 pf \pm 5%, 500 vdcw	00853	0140-0082	1	1		
C223	Capacitor: fixed, mylar, 0.1 μ f \pm 20%, 100 vdcw	56289	0170-0055	1	1		
C224	Same as C204						
C225 thru C300	Not assigned						
C301	Same as C122						

* See introduction to this section

Table 5-1. Replaceable Parts (Cont'd)

Ckt Ref.	Description	Mfr *	Ⓜ Stock No.	TQ*	RS*		
C302	Capacitor: fixed, paper, 1500 pf ± 10%, 600 vdcw	56289	0160-0012	1	1		
C303	Same as C122						
C304	Capacitor: fixed, ceramic, 0.05 μf ± 20%, 400 vdcw	56289	0150-0052	1	1		
CR1,2	Diode, silicon: 1N1566A	04713	1901-0006	2	2		
CR3	Diode, selenium	77638	1883-0005	1	1		
CR4 thru CR100	Not assigned						
CR101	Diode, selenium	00891	1883-0006	1	1		
CR102 thru CR106	Diode, silicon: RCA	02735	1901-0029	7	7		
CR107 thru CR200	Not assigned						
CR201 thru CR203	Diode, germanium	73293	1910-0011	3	3		
CR204	Diode, silicon	28480	G-31G-56A	1	1		
CR205 thru CR300	Not assigned						
CR301	Diode, silicon	28480	G-29E-2	1	1		
CR302, 303	Same as CR102						
CR304	Diode, germanium: 1N90	73293	1910-0004	1	1		
DS1	Lamp, incandescent: 0.15 amp, 6-8V, #47	24455	2140-0009	1	1		
F1 thru F100	Not assigned						
F101,102	Fuse: 3 amp, 3 AG 115V or 230V operation	75915	2110-0003	2	2		
J1 thru J100	Not assigned						
J101	RF output: part of BWO tube assembly; component not separately replaceable						

* See introduction to this section

Table 5-1. Replaceable Parts (Cont'd)

Ckt Ref.	Description	Mfr *	hp Stock No.	TQ*	RS*		
J102 thru J200	Not assigned						
J201 thru J203	Connector, female: BNC	91737	1250-0001	4	1		
J204 thru J300	Not assigned						
J301	Same as J201						
K1 thru K100	Not assigned						
K101, 102	Relay armature: DPDT, 1.5 amp Delayed Turn-On Relay; Helix Overload Holdoff Relay	70119	0490-0008	2	1		
K103	Relay armature: SPDT, 2 amps Helix Overload Relay	77342	0490-0019	1	1		
L1	BWO Magnet	28480	9161-0007	1	1		
L2 thru L100	Not assigned						
L101	Inductor: 118 mh	98405	9140-0006	1	1		
M1 thru M100	Not assigned						
M101	Meter	28480	1120-0063	1	1		
R1,2	Resistor: fixed, wirewound, 9 ohms $\pm 10\%$, 5 W	35434	0813-0016	4	1		
R3	Resistor: fixed, composition, 100 ohms $\pm 10\%$, 1/2 W	01121	0687-1011	4	1		
R4,5	Resistor: fixed, composition, 47 ohms $\pm 10\%$, 2 W	01121	0693-4701	5	2		
R6,7	Same as R3						
R8,9	Same as R4						
R10	Same as R3						
R11	Resistor: fixed, composition, 220,000 ohms $\pm 10\%$, 1/2 W	01121	0687-2241	4	1		
R12,13	Resistor: fixed, wirewound, 15 ohms $\pm 10\%$, 20 W Optimum value selected at factory. Average value shown.	35434	0819-0012	2	1		
R14 thru R17	Resistor: fixed, wirewound, 1000 ohms $\pm 5\%$, 40 W Optimum value selected at factory. Average value shown.	94310	0818-0014	4	1		

* See introduction to this section

Table 5-1. Replaceable Parts (Cont'd)

Ckt Ref.	Description	Mfr *	Ⓜ Stock No.	TQ*	RS*		
R18, 19	Resistor: fixed, composition, 390,000 ohms $\pm 10\%$, 1/2 W	01121	0687-3941	4	1		
R20	Same as R4						
R21	Resistor: fixed, wirewound, 10,000 ohms $\pm 10\%$, 5 W	83777	0813-0007	2	1		
R22	Resistor: fixed, composition, 680,000 ohms $\pm 10\%$, 1/2 W	01121	0687-6841	4	1		
R23	Resistor: fixed, composition, 180,000 ohms $\pm 10\%$, 1/2 W	01121	0687-1841	3	1		
R24	Same as R22						
R25	Same as R23 Optimum value selected at factory. Average value shown.						
R26	Resistor: fixed, composition, 33,000 ohms $\pm 10\%$, 1/2 W	01121	0687-3331	3	1		
R27	Resistor: 0.073 ohms, Shunt "A"	28480	686A-26A	1	1		
R28	Resistor: fixed, wirewound, 14 ohms $\pm 10\%$, 10 W	35434	0816-0019	2	1		
R29	Resistor: fixed, composition, 15 megohms $\pm 10\%$, 1/2 W	01121	0687-1561	1	1		
R30	Resistor: variable, composition, linear taper, 500,000 ohms $\pm 30\%$, 1/5 W	71450	2100-0181	2	1		
R31	Same as R18						
R32	Resistor: fixed, composition, 39 ohms $\pm 10\%$, 2 W Optimum value selected at factory. Average value shown.	01121	0693-3901	1	1		
R33	Resistor: fixed, composition, 1 megohm $\pm 10\%$, 1/2 W	01121	0687-1051	10	3		
R34	Same as R23						
R35	Tube, ballast: #15-4	70563	0852-0008	1	1		
R36	Tube, ballast: glass, octal base, #12-4	70563	0852-0001	1	1		
R37	Resistor: fixed, composition, 56 ohms $\pm 10\%$, 2 W Optimum value selected at factory. Average value shown.	01121	0693-5601	1	1		

* See introduction to this section

Table 5-1. Replaceable Parts (Cont'd)

Ckt Ref.	Description	Mfr *	hp Stock No.	TQ*	RS*		
R38	Resistor: fixed, composition, 100 ohms $\pm 10\%$, 2 W Optimum value selected at factory. Average value shown.	01121	0693-1011	1	1		
R39	Same as R28 Optimum value selected at factory. Average value shown.						
R40	Resistor: fixed, composition, 2.7 ohms $\pm 10\%$, 1 W Optimum value selected at factory. Average value shown.	01121	0699-0005	1	1		
R41, 42	Same as R1						
R43	Thermistor	24446	0839-0006	1	1		
R44 thru R100	Not assigned						
R101	Resistor: fixed, wirewound, 7500 ohms $\pm 10\%$, 10 W	35434	0816-0007	1	1		
R102	Resistor: fixed, composition, 100 ohms $\pm 10\%$, 1 W	01121	0690-1011	3	1		
R103	Resistor: fixed, composition, 2200 ohms $\pm 10\%$, 1 W	01121	0690-2221	2	1		
R104	Resistor: fixed, composition, 100,000 ohms $\pm 10\%$, 1 W	01121	0690-1041	1	1		
R105	Same as R102						
R106 thru R108	Resistor: fixed, composition, 1.8 megohms $\pm 10\%$, 2 W	01121	0693-1851	3	1		
R109, 110	Resistor: fixed, composition, 820,000 ohms $\pm 10\%$, 1 W	01121	0690-8241	2	1		
R111	Resistor: fixed, composition, 220 ohms $\pm 10\%$, 1/2 W	01121	0687-2211	1	1		
R112	Resistor: fixed, composition, 1800 ohms $\pm 10\%$, 1/2 W	01121	0687-1821	1	1		
R113	Same as R102						
R114	Not assigned						
R115	Resistor: fixed, composition, 39,000 ohms $\pm 10\%$, 1/2 W Optimum value selected at factory. Average value shown.	01121	0687-3931	1	1		
R116 thru R119	Resistor: fixed, composition, 470,000 ohms $\pm 10\%$, 2 W	01121	0693-4741	8	2		

* See introduction to this section

Table 5-1. Replaceable Parts (Cont'd)

Ckt Ref.	Description	Mfr *	Ⓜ Stock No.	TQ*	RS*		
R120	Resistor: fixed, composition, 10 ohms $\pm 10\%$, 1 W	01121	0690-1001	1	1		
R121	Not assigned						
R122	Resistor: fixed, metal film, 450,000 ohms $\pm 5\%$, 1 W	15909	0761-0002	2	1		
R123	Resistor: 7.15 ohms, Shunt "B"	28480	686A-26B	2	1		
R124, 125	Resistor: 50 ohms, Shunt "C"	28480	686A-26C	2	1		
R126	Same as R123						
R127, 128	Resistor: fixed, composition, 1.5 megohms $\pm 10\%$, 1/2 W	01121	0687-1551	5	2		
R129, 130	Resistor: fixed, composition, 150,000 ohms $\pm 10\%$, 1/2 W	01121	0687-1541	4	1		
R131	Resistor: fixed, composition, 2200 ohms $\pm 10\%$, 1/2 W	01121	0687-2221	2	1		
R132	Resistor: variable, composition, linear taper, 3 megohms $\pm 20\%$, 2 W	71450	2100-0046	1	1		
R133	Resistor: fixed, composition, 330,000 ohms $\pm 10\%$, 1 W	01121	0690-3341	1	1		
R134	Resistor: fixed, composition, 68,000 ohms $\pm 10\%$, 1 W	01121	0690-6831	1	1		
R135	Resistor: variable, composition, linear taper, 500,000 ohms $\pm 10\%$, 2 W	01121	2100-0043	1	1		
R136	Not assigned						
R137	Resistor: fixed, composition, 15,000 ohms $\pm 10\%$, 1/2 W	01121	0687-1531	3	1		
R138	Resistor: fixed, composition, 180,000 ohms $\pm 10\%$, 2 W	01121	0693-1841	1	1		
R139	Same as R33						
R140	Resistor: fixed, composition, 120,000 ohms $\pm 10\%$, 1/2 W	01121	0687-1241	2	1		
R141	Resistor: variable, composition, 50,000 ohms $\pm 30\%$, 1/4 W	71450	2100-0094	2	1		
R142	Resistor: fixed, composition, 270,000 ohms $\pm 10\%$, 1/2 W	01121	0687-2741	2	1		
R143	Same as R26						
R144	Resistor: fixed, composition, 47,000 ohms $\pm 10\%$, 1/2 W	01121	0687-4731	2	1		

* See introduction to this section

Table 5-1. Replaceable Parts (Cont'd)

Ckt Ref.	Description	Mfr *	Ⓟ Stock No.	TQ*	RS*		
R145	Resistor: fixed, wirewound, 20,000 ohms $\pm 10\%$, 10 W	35434	0816-0018	1	1		
R146	Resistor: fixed, composition, 470,000 ohms $\pm 10\%$, 1/2 W	01121	0687-4741	3	1		
R147	Resistor: fixed, composition, 100,000 ohms $\pm 10\%$, 1/2 W	01121	0687-1041	5	2		
R148	Same as R141						
R149	Resistor: fixed, composition, 56,000 ohms $\pm 10\%$, 1/2 W	01121	0687-5631	1	1		
R150	Resistor: fixed, deposited carbon, 600,000 ohms $\pm 5\%$, 1 W	19701	0730-0095	2	1		
R151	Same as R122						
R152	Resistor: fixed, composition, 10 megohms $\pm 10\%$, 1/2 W	01121	0687-1061	1	1		
R153	Resistor: fixed, composition, 22 megohms $\pm 10\%$, 1/2 W	01121	0687-2261	3	1		
R154	Same as R150						
R155 thru R157	Not assigned						
R158	Resistor: fixed, composition, 150,000 ohms $\pm 10\%$, 2 W	01121	0693-1541	1	1		
R159 thru R165	Not assigned						
R166	Resistor: fixed, composition, 47 ohms $\pm 10\%$, 1 W	01121	0690-4701	2	1		
R167, 168	Same as R116						
R169	Same as R166						
R170, 171	Same as R116						
R172, 173	Not assigned						
R174	Resistor: fixed, composition, 47,000 ohms $\pm 10\%$, 1 W	01121	0690-4731	1	1		
R175	Resistor: fixed, composition, 82,000 ohms $\pm 10\%$, 1 W	01121	0690-8231	2	1		
R176 thru R200	Not assigned						
R201	Same as R153						

* See introduction to this section

Table 5-1. Replaceable Parts (Cont'd)

Ckt Ref.	Description	Mfr *	Ⓢ Stock No.	TQ*	RS*		
R202	Resistor: fixed, composition, 8.2 megohms $\pm 10\%$, 1/2 W	01121	0687-8251	1	1		
R203	Same as R30						
R204	Same as R33						
R205	Resistor: fixed, composition, 3.3 megohms $\pm 10\%$, 1/2 W	01121	0687-3351	2	1		
R206	Same as R137						
R207	Resistor: fixed, composition, 6800 ohms $\pm 10\%$, 1/2 W	01121	0687-6821	1	1		
R208	Resistor: fixed, composition, 1500 ohms $\pm 10\%$, 1/2 W	01121	0687-1521	2	1		
R209	Resistor: fixed, composition, 27,000 ohms $\pm 5\%$, 1/2 W	01121	0686-2735	1	1		
R210	Resistor: fixed, metal film, 600,000 ohms $\pm 1/2\%$, 1/2 W	65092	0757-0016	1	1		
R211	Resistor: fixed, deposited carbon, 1.5 megohms $\pm 1\%$, 1/2 W	19701	0727-0282	1	1		
R212	Resistor: fixed, deposited carbon, 265,000 ohms $\pm 1\%$, 1/2 W Optimum value selected at factory. Average value shown.	19701	0727-0229	1	1		
R213	Resistor: fixed, deposited carbon, 1.75 megohms $\pm 1\%$, 1/2 W	19701	0727-0284	1	1		
R214	Same as R147						
R215	Same as R33						
R216	Resistor: fixed, composition, 150,000 ohms $\pm 10\%$, 1 W	01121	0690-1541	2	1		
R217	Resistor: variable, composition, linear taper, 1 megohm $\pm 30\%$, 0.2 W	71450	2100-0080	4	1		
R218	Resistor: fixed, composition, 560,000 ohms $\pm 10\%$, 1/2 W	01121	0687-5641	1	1		
R219	Same as R22						
R220	Same as R147						
R221	Same as R142						
R222	Same as R140						
R223, 224	Resistor: fixed, composition, 10,000 ohms $\pm 10\%$, 1/2 W	01121	0687-1031	3	1		

* See introduction to this section

Table 5-1. Replaceable Parts (Cont'd)

Ckt Ref.	Description	Mfr *	Ⓢ Stock No.	TQ*	RS*		
R225 thru R227	Resistor: variable, composition, linear taper, 50,000 ohms $\pm 20\%$, 1/4 W	71450	2100-0141	3	1		
R228	Resistor: fixed, composition, 27,000 ohms $\pm 10\%$, 1/2 W	01121	0687-2731	1	1		
R229	Resistor: variable, composition, linear taper, 5 megohms $\pm 20\%$, 1/4 W	71450	2100-0066	1	1		
R230	Resistor: fixed, deposited carbon, 4.9 megohms $\pm 1\%$, 1/2 W	19701	0727-0299	1	1		
R231	Resistor: fixed, deposited carbon, 15.7 megohms $\pm 1\%$, 1 W	95236	0730-0146	1	1		
R232	Same as R205 Optimum value selected at factory. Average value shown.						
R233	Resistor: fixed, composition, 12,000 ohms $\pm 10\%$, 1/2 W	01121	0687-1231	1	1		
R234	Resistor: fixed, deposited carbon, 200,000 ohms $\pm 1\%$, 1/2 W. Optimum value selected at factory. Average value shown.	19701	0727-0221	1	1		
R235	Same as R21						
R236	Resistor: variable, wirewound, linear taper, 100,000 ohms $\pm 5\%$, 8 W	99957	2100-0042	1	1		
R237	Same as R127						
R238	Same as R33						
R239	Same as R18						
R240	Resistor: fixed, deposited carbon, 144,000 ohms $\pm 1\%$, 1 W	19701	0730-0074	1	1		
R241	Same as R208 Optimum value selected at factory. Average value shown.						
R242	Same as R33						
R243	Resistor: fixed, composition, 270,000 ohms $\pm 10\%$, 1 W	01121	0690-2741	1	1		
R244	Resistor: variable, composition, linear taper, 200,000 ohms $\pm 30\%$, 1/4 W	71450	2100-0164	1	1		
R245	Same as R217						
R246	Resistor: variable, composition, linear taper, 3 megohms $\pm 30\%$, 1/4 W	71450	2100-0165	2	1		

* See introduction to this section

Table 5-1. Replaceable Parts (Cont'd)

Ckt Ref.	Description	Mfr *	Ⓜ Stock No.	TQ*	RS*		
R247	Resistor: variable, composition, linear taper, 10 megohms $\pm 30\%$, 1/4 W	71450	2100-0040	2	1		
R248	Same as R217						
R249	Same as R246						
R250	Same as R247						
R251	Same as R217						
R252	Same as R146						
R253	Same as R127						
R254	Same as R127 Optimum value selected at factory. Average value shown.						
R255	Resistor: fixed, composition, 5.6 megohms $\pm 10\%$, 1/2 W	01121	0687-5651	1	1		
R256	Resistor: fixed, composition, 4.7 megohms $\pm 10\%$, 1/2 W Optimum value selected at factory. Average value shown.	01121	0687-4751	1	1		
R257	Same as R147						
R258	Same as R131						
R259	Resistor: fixed, deposited carbon, 46.74 megohms $\pm 1\%$, 2 W	19701	0733-0011	1	1		
R260	Resistor: fixed, composition, 130,000 ohms $\pm 5\%$, 1/2 W	01121	0686-1345	1	1		
R261, 262	Resistor: fixed, composition, 39,000 ohms $\pm 10\%$, 1/2 W	01121	0687-3931	2	1		
R263	Resistor: fixed, composition, 200,000 ohms $\pm 5\%$, 1/2 W	01121	0686-2045	1	1		
R264	Same as R146						
R265 thru R300	Not assigned						
R301	Same as R153						
R302	Resistor: variable, composition, 3.5 megohms $\pm 20\%$, 1/4 W	71450	2100-0162	1	1		
R303	Resistor: fixed, composition, 100,000 ohms $\pm 5\%$, 1/2 W	01121	0686-1045	2	1		
R304	Same as R103						

* See introduction to this section

Table 5-1. Replaceable Parts (Cont'd)

Ckt Ref.	Description	Mfr *	hp Stock No.	TQ*	RS*		
R305	Same as R216						
R306	Resistor: fixed, composition, 2.2 megohms $\pm 10\%$, 1 W	01121	0690-2251	1	1		
R307	Resistor: fixed, composition, 1.2 megohms $\pm 10\%$, 1 W	01121	0690-1251	1	1		
R308	Resistor: fixed, composition, 12,000 ohms $\pm 10\%$, 1 W	01121	0690-1231	1	1		
R309	Resistor: fixed, composition, 680,000 ohms $\pm 10\%$, 1 W	01121	0690-6841	1	1		
R310	Resistor: variable, composition, linear taper, 1 megohm $\pm 30\%$, 1/4 W	71450	2100-0096	3	1		
R311	Resistor: fixed, composition, 1.5 megohms $\pm 10\%$, 1 W	01121	0690-1551	1	1		
R312	Same as R33						
R313	Resistor: fixed, composition, 750,000 ohms $\pm 5\%$, 1/2 W Optimum value selected at factory. Average value shown.	01121	0686-7545	1	1		
R314	Not assigned						
R315	Same as R310						
R316	Same as R33						
R317	Same as R223						
R318	Same as R175 Optimum value selected at factory. Average value shown.						
R319	Same as R26						
R320	Resistor: variable, composition, 20,000 ohms $\pm 20\%$, 1/4 W	71450	2100-0093	1	1		
R321	Same as R310						
R322	Same as R129						
R323	Resistor: fixed, composition, 68,000 ohms $\pm 10\%$, 1/2 W	01121	0687-6831	2	1		
R324	Resistor: variable, composition, 100,000 ohms $\pm 30\%$, 1/4 W	71450	2100-0095	2	1		
R325	Same as R144						
R326	Same as R303						

* See introduction to this section

Table 5-1. Replaceable Parts (Cont'd)

Ckt Ref.	Description	Mfr *	Ⓟ Stock No.	TQ*	RS*		
R327	Part of S302; component not separately replaceable						
R328	Not assigned						
R329	Same as R22						
R330	Resistor: fixed, composition, 220,000 ohms $\pm 10\%$, 2 W	01121	0693-2241	1	1		
R331	Same as R147						
R332	Same as R324						
R333	Same as R137						
R334	Resistor: fixed, composition, 68,000 ohms $\pm 10\%$, 2 W	01121	0693-6831	1	1		
R335	Resistor: variable, composition, linear taper, 250,000 ohms $\pm 30\%$	71450	2100-0144	1	1		
R336	Same as R323						
R337	Same as R11						
R338, 339	Same as R33						
R340	Same as R129						
R341, 342	Same as R11						
S1 thru S100	Not assigned						
S101	Switch, toggle: SPST	04009	3101-0030	1	1		
S102	Switch, Thermal Delay: SPST	70563	0490-0019	1	1		
S103	Switch, rotary: 2 section, 5 position	71590	3100-0161	1	1		
S104 thru S200	Not assigned						
S201	Switch, push: SPDT (manual trigger)	82389	3101-0004	1	1		
S202	Switch, rotary: (sweep selector)	76854	3100-0163	1	1		
S203	Switch, rotary	76854	3100-0160	1	1		
S204	Switch, rotary	76854	3100-0162	1	1		
S205 thru S300	Not assigned						
S301	Amplitude Mod. Switch Assembly	28480	682C-19A	1	1		

* See introduction to this section

Table 5-1. Replaceable Parts (Cont'd)

Ckt Ref.	Description	Mfr *	Ⓢ Stock No.	TQ*	RS*		
S302	RF Leveler Switch Assembly	28480	682C-19B	1	1		
T1	Transformer, power	28480	9100-0086	1	1		
T2 thru T100	Not assigned						
T101	Transformer, power	28480	9100-0085	1	1		
V1,2	Tube, electron: 6080	80131	1932-0010	2	2		
V3	Tube, electron: OA2	80131	1940-0004	2	2		
V4	Tube, electron: 6DJ8/ECC88	80131	1932-0022	7	7		
V5	Tube, electron: 12AX7	80131	1932-0030	1	1		
V6 thru V11	Lamp, neon: selected, aged and tested NE2 (blue)	28480	G-84B	8	8		
V12 thru V100	Not assigned						
V101	Tube, electron: 6293	80131	1923-0007	1	1		
V102	Tube, electron: 6350	80131	1932-0013	1	1		
V103	Tube, electron: 7239	80131	1923-0045	1	1		
V104	Tube, electron: BWO	05783	1951-0011	1	1		
V105	Tube, electron: 12AT7	80131	1932-0027	1	1		
V106	Tube, electron: 12B4A	80131	1921-0010	1	1		
V107	Tube, electron: 6U8	80131	1933-0004	3	3		
V108	Tube, electron: 5651	80131	1940-0001	1	1		
V109	Same as V107						
V110	Lamp, neon: selected, aged and tested NE2 (red)	28480	G-84E	2	2		
V111 thru V200	Not assigned						
V201,202	Same as V4						
V203	Tube, electron: 6AL5	80131	1930-0013	2	2		
V204	Tube, electron: 6AN8	80131	1933-0001	1	1		
V205	Same as V203						
V206	Same as V3						
V207	Same as V4						

* See introduction to this section

Table 5-1. Replaceable Parts (Cont'd)

Ckt Ref.	Description	Mfr *	Ⓜ Stock No.	TQ*	RS*		
V208	Same as V107						
V209,210	Same as V6						
V211	Same as V110						
V212 thru V300	Not assigned						
V301 thru V303	Same as V4						
W1 thru W100	Not assigned						
W101	Cable, power	70903	8120-0015	1	1		
	<u>MISCELLANEOUS</u>						
	Ceramic plate cap: 3/8 in.	76487	1401-0006	1	1		
	Ceramic plate cap: 1/4 in.	76487	1401-0007	1	1		
	Cronac spring	0000C	1460-0005	1	1		
	Filter, air	82866	3150-0005	1	1		
	Fuseholder	75915	1400-0056	1	1		
	Fuseholder	75915	1400-0084	1	1		
	Knob: CATHODE CURRENT	28480	G-74K	1	0		
	Knob, bar: CURRENT, SWEEP SELECTOR, RF SWEEP RATE	28480	G-74N	3	0		
	Knob, bar: ANODE MOD. SELECTOR, Δ FREQUENCY (MC)	28480	G-74Q	2	0		
	Knob: FREQUENCY DIAL	28480	G-74Z	1	0		
	Knob: FREQUENCY VERNIER	28480	G-74F	1	0		
	Knob, red: INT SQUARE WAVE FREQUENCY, Δ FREQUENCY (MC) VERNIER	28480	G-74AV	2	0		
	Lampholder	95263	1450-0008	1	1		
	Precalibrated Dial Assembly	28480	683A-40A	1	0		
	Socket (BWO supply)	0000L	1251-0044	1	1		
	Tube socket: (V105)	71785	1200-0003	1	1		

* See introduction to this section

Table 5-1. Replaceable Parts (Cont'd)

Ckt Ref.	Description	Mfr *	Ⓢ Stock No.	TQ*	RS*		
	Tube socket: V4, V5, V102, V104, V106, V107, V109, V201, V202, V204, V301 thru V303	71785	1200-0008	14	1		
	Tube socket: V3, V103, V108, V203, V205, V208	91662	1200-0009	6	1		
	Tube socket: R35, R36, V1, V2, V101	71785	1200-0020	5	1		
	Tube Clamp	91506	1400-0019	5	0		
	Tube Clamp	91506	1400-0033	2	0		
	Window, dial	28480	G-99K	1	0		

* See introduction to this section